

DUOVENT® COMPACT RV TOP



Digireg®

Rotating
exchanger

EC motor



ErP conform

VAV-CAV-COP
control typesmax. regeneration
efficiency

Technical Parameters

Cabinet

Patented ISOSTREAM® Cabinet is built out of aluminum profiles to which individual panels are attached by screws. The panels are made out of galvanized sheet metal with wall thickness of 45 mm and finished with external grey-white paint, type RAL9002. Optional anti-corrosion surface protection is available upon request. The panels are lined with non-flammable mineral wool core and sandwiched from both sides. All panels are removable and selected panels are equipped with hinges and locks to provide for easy service access. Top of the cabinet comes with either square or rectangular air inlets and outlets opening. In location where condensation will occur cabinets are fitted with a condensate pan with drain outlet.

Fans

Centrifugal, backward-curve blades design with impeller made out of composite materials. Each fan comes statically and dynamically balanced.

Motors

Direct drive EC motors. Each motor can be continuously controlled by external 0...10V signal, comes with built-in thermal protection. Motor efficiency class is rated IE4, electric motor insulation protection is IP54.

RW Heat Exchanger

Rotating Wheel heat exchanger can transfer heat or heat and humidity simultaneously. It is designed for ambient temperatures running between -20 °C to +55 °C. Wheel is coiled from layers of aluminum foil with standard layer span of 1,6 mm. Wheel's casing is supported by galvanized profiles. Brush seal provides a tight seal between rotor and its casing. Where needed, labyrinth seal with air leakage rate less than 1.5 % can be used. The rotating wheel is driven by electric motor, worm transmission with pulley and belt. Power supply requirement: 1x 230V/50Hz or 3x 230V/50Hz. 0 to 10V continuous speed controller comes as an option.

Filters

Fresh air intake and return air inlet come fitted with 96 mm wide filter bracket which can be equipped with filters rated from G4 to F9. Where multi-stage filtration is required additional MFL filter cartridges with MFR inserts are available. This type of filtration system is intended to be mounted in ductwork. Filter access is provided by service doors.

Power Supply

3x 400V/50Hz. Control wires and line voltage cables are installed running through plastic penetration inlets pre-drilled in panels and through rubber penetration gromets with membrane running on the inside of unit.

Control

In standard configuration Digireg® control system enclosure comes mounted to the unit's mid panel with all internal wiring completed and with control board preprogrammed based on unit's configuration. Any other mounting location can be done per request. QC running test is performed before each unit leaves the manufacturing plant.

Installation

Installed in vertical position sitting on a floor or vertical position sitting on building's roof. Unit's inlet and outlet openings must be placed in consideration when installing the unit. Service access must be sufficient in order to open service door and replace filters. Digireg must be accessible for any future service work. Adequate space below the unit must be maintained in order to connect to condensate drain outlets and install drain traps. Condensate drain needs to slope at 5 degrees towards the condensate discharge. Refrigeration lines are to be connected to prefabricated square neck mounted in panel. Flexible pipe connections and flexible duct connections are recommended in order to eliminate any vibrations coming from the unit.

Noise

Noise data as listed in acoustic tables represent acoustic output levels at individual inlets/outlets, including tolerance for weight filter A. The table includes acoustic noise level incorporating casing of the unit and reads noise level when measured 1 m from the service side of the unit, in open field Q=2. The acoustic readings come within ±3 dB tolerance.

Unit Configuration

Unit's individual configuration and its accessories are identified by a specific code number which is part of model number. Any non-typical, custom unit configuration needs to be consulted prior to ordering unit.

HVAC accessories

- Sonoflex®, Thermoflex®, flexible hoses and fittings
- SPIRO round spiro pipes and fittings

- KAA, IAE flexible couplings
- MAA, MTS noise silencers
- RSK, TSK check flap
- MSK, IJK throttle and mixing flaps disc valves, diffusers, nozzles, grilles rain louvres
- MBE, IBE, IBW, MBW electric and water heaters for round and square pipes
- MKW, IKW, IKF, MKF water coolers and direct evaporators for round and square pipes
- MFL, IFL filter cartridges for round and square pipes
- ESU mixing nozzles

Electrical Accessory

- Digireg® digital control system for units equipped with heating and cooling, controller with touch-screen display (K9)
- JTR triac switch for electric heater control (K9)
- HIG, HYG hygostats (K8.2)
- AIRSENS, EDF-CO2, SQA sensors CO₂ (K8.2)
- RTR thermostats (K8.2)
- DTS PSA pressure sensors (K8.2)
- Servo-drives (K8.2)

Information

The unit is designed for ventilation of commercial areas. Mounting variants allow adaptation to the requirements of the building. The unit is intended to permanent operation.

Warranty Terms

DUOVENT® MODULAR RV equipment, incl. its DVAV, DCAV, DCOP and MVAV systems, must be commissioned by a factory authorized service technician. Failure to provide factory authorized commissioning will lead to termination of rights of the Buyer and will void the unit's warranty.

Type key for ordering

DUOVENTCOMPACTRV 4200TDI DXMXKL G4+F7/M5 DVAVLTOP
 1 2 3 4 5 6 7 8 9 10

- 1 – unit size – **800, 1800, 3000, 4200, 6000**
- 2 – type of rotating wheel:
T – temperature
E – enthalpy
S – sorption
- 3 – type of heating:
DI – electric
DCA – water, temperature gradient 80/60°C
DCB – water, temperature gradient 45/35°C
- 4 – type of cooling:
DCC – water, temperature gradient 6/12°C
DX – direct evaporation coil, R410A or R32 refrigerant, evaporation temperature 6°C (When using DX coil we must specify type of refrigerant, cooling capacity and amount of cooling circuits based on type of condensing unit being used)
 Use of heat pump needs to be specified in the order.
DXr – direct evaporation cooling coil use for heating and cooling, R410A or R32 refrigerant

- 5 – **MX** – mixing air damper, without actuator (when unit is ordered with Digireg MAR system, the power actuator becomes part of delivery)
C – mixing air damper designed for 100% air recirculation (when unit is ordered with Digireg MAR system, the power actuator becomes part of delivery)
- 6 – **KL** – outside air and return air dampers, without actuators (when unit is ordered with Digireg MAR system, the power actuator becomes part of delivery)
- 7 – classification of air filters for outside air and return air inlets (G4–F9)
- 8 – type of unit control system:
D – Digireg®
- 9 – type of airflow regulation:
VAV – variable air volume
CAV – constant air volume
COP – constant operating pressure
- 10 – placement of unit's inlets and outlets

Order examples

DUOVENT COMPACT RV 4200T DI DX MX KL G4+F7/M5 DVAV L TOP

Unit size 4200, with temperature controlled rotating wheel heat exchanger, electric heat strip, DX coil, mixing air damper, two stage (G4 and F7) filter configuration on SA side/ single stage M5 filter on RA side. Digireg controls with VAV air flow. Left neck position.

DUOVENT COMPACT RV 800 E DCA F7/M5 DVAV P TOP

Unit size 800 with enthalpy controlled rotating wheel. Hot water coil 80/60, no dampers, F7 supply air filter and M5 return air filter. Digireg with VAV air flow. Right neck position.

Class acc. to EN779	Class acc. to EN ISO 16890
G4	ISO Coarse 60%
M5	ISO eM10 50%
F7	ISO eM2,5 70%
F9	ISO eM1 80%

Type	Nominal flow [m³/h]	voltage [V]	Inlet/exhaust fan		heater		cooler power* [kW]	efficiency* [%]	unit max. air flow [m³/h]	control system Digireg®	weight without MX/ with MX**
			max. input power [W]	current [A]	power* [kW]	current [A]					
800	800	1×230V/50Hz	418/372	1,8/1,6	/	/	/	78,5	800	M1-Vx	186-200/ 195-205
800 DCA					4,7	/	/				
800 DCB					3,1	/	/				
800 DCA DCC					4,7	/	5,2				
800 DCA DX					4,7	/	5,8				
800 DI					3	13	/				
1800	1800	3×400V/50Hz	1005/736	1,6/1,2	/	/	/	77	2000	M3-Vx	358-370/ 371-385
1800 DCA					11,7	/	/				
1800 DCB					7,8	/	/				
1800 DCA DCC					11,7	/	15,4				
1800 DCA DX					11,7	/	13,5				
1800 DI					7,5	10,8	/				
3000	3000	3×400V/50Hz	1422/1085	2,2/1,7	/	/	/	76,3	3500	M3-Vx	430-446/ 465-482
3000 DCA					18,2	/	/				
3000 DCB					13,3	/	/				
3000 DCA DCC					18,2	/	23,8				
3000 DCA DX					18,2	/	23,7				
3000 DI					15	21,7	/				
4200	4200	3×400V/50Hz	1930/1478	3/2,3	/	/	/	76,6	4500	M3-Vx	545-570/ 580-610
4200 DCA					26,5	/	/				
4200 DCB					17,7	/	/				
4200 DCA DCC					26,5	/	33,4				
4200 DCA DX					26,5	/	32,7				
4200 DI					15	21,7	/				
6000	6000	3×400V/50Hz	2829/2106	4,5/3,4	/	/	/	76,5	6000	M3-Vx	638-674/ 735-772
6000 DCA					36,5	/	/				
6000 DCB					26,6	/	/				
6000 DCA DCC					36,5	/	45				
6000 DCA DX					36,5	/	45				
6000 DI					22,5	32,5	/				

* At nominal air flow, $t_s = -12^\circ\text{C}/90\%$ r.h., $t_i = 22^\circ\text{C}/50\%$ r.h., $t_e = 35^\circ\text{C}/35\%$ r.h. (SUMMER), temperature rotor.

** Depending on particular variant.

Water cooler power DCC for $t_s = 35^\circ\text{C}/35\%$ r.h, $t_w = 6/12^\circ\text{C}$. Water heater power DCA for $t_s = 12^\circ\text{C}$, $t_w = 80/60^\circ\text{C}$.

Water heater power DCB for $t_s = 12^\circ\text{C}$, $t_w = 45/35^\circ\text{C}$. Direct evaporating unit power DX for R410A coolant, $t_s = 35^\circ\text{C}/35\%$ r.h., $t_{wp} = 6^\circ\text{C}$.

Dimensions of units DUOVENT® Compact RV TOP without mixing clap (drawn position „L“):

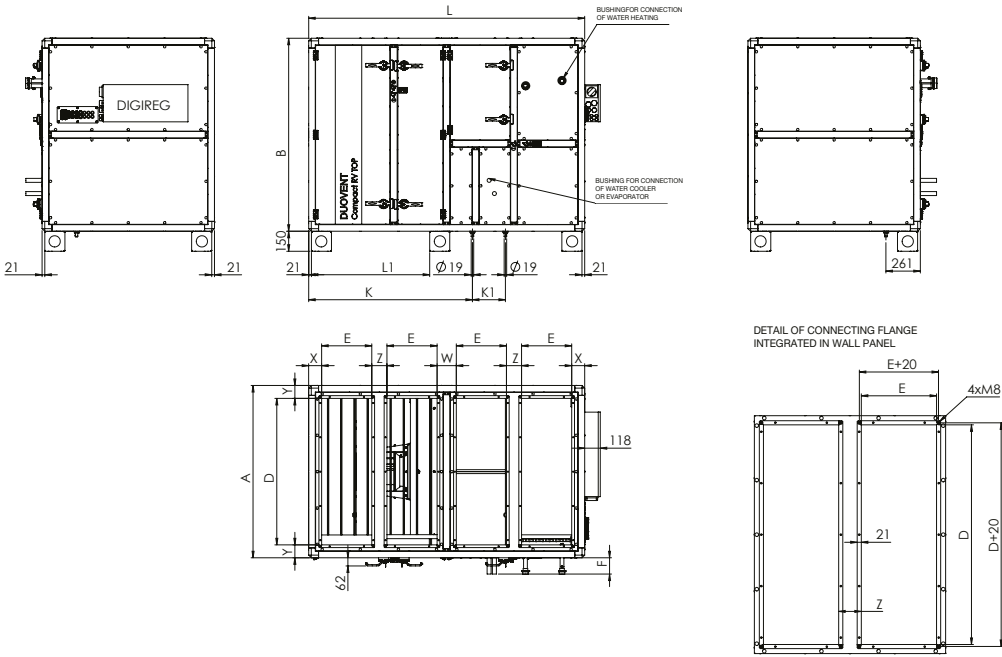

Size	A [mm]	B [mm]	D [mm]	E [mm]	F [mm]	L [mm]	L1* [mm]	K [mm]	K1 [mm]	X [mm]	Y [mm]	W [mm]	Z [mm]
800	678	914	480	190	65	1306	–	832	160	98	99	145	102
1800	992	1149	790	250	80	1620	–	1002	180	98	101	145	139
3000	1149	1306	950	300	80	1777	–	1072	230	98	100	145	117
4200	1306	1463	1110	380	80	2091	916	1240	250	98	98	145	114
6000	1463	1620	1260	420	80	2248	967	1320	250	98	101	145	113

* Sizes 800,1800 and 3000 do not have middle leg.

Dimensions of units DUOVENT® Compact RV TOP with mixing clap (drawn position „L“):

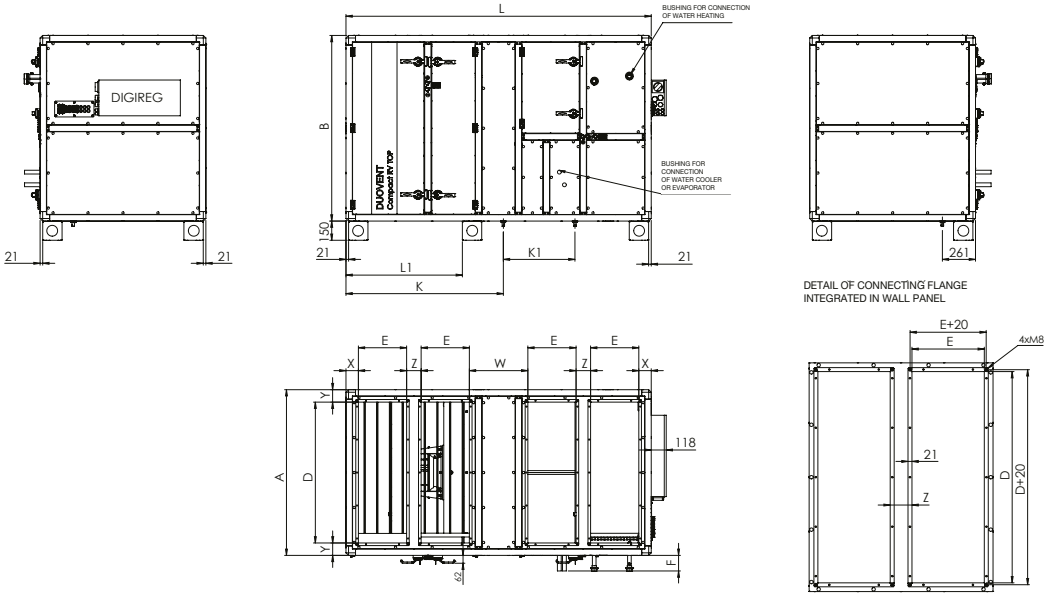

Size	A [mm]	B [mm]	D [mm]	E [mm]	F [mm]	L [mm]	L1* [mm]	K [mm]	K1 [mm]	X [mm]	Y [mm]	W [mm]	Z [mm]
800	678	914	480	190	65	1463	-	832	310	98	99	301	102
1800	992	1149	790	250	80	1777	-	1002	320	98	101	301	139
3000	1149	1306	950	300	80	2091	-	1072	530	98	100	460	117
4200	1306	1463	1110	380	80	2405	916	1240	565	98	98	460	114
6000	1463	1620	1260	420	80	2562	967	1320	620	98	101	460	113

* Sizes 800,1800 and 3000 do not have middle leg.

Service space for operation and repair of Duovent® Compact RV TOP units

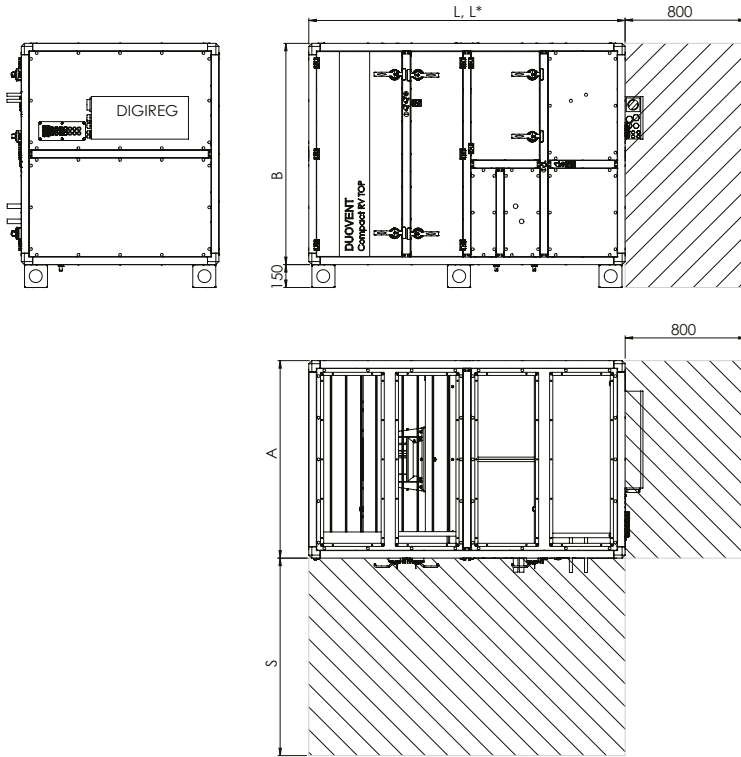

Size	A [mm]	L [mm]	L* [mm]	S [mm]
800	678	1306	1463	700
1800	992	1620	1777	1000
3000	1149	1777	2091	1200
4200	1306	2091	2405	1350
6000	1463	2248	2562	1500

L – unit length without mixing clap

L* – unit length with mixing clap

Arrangement diagram of components of Duovent® Compact RV TOP units without mixing (left position „L“)

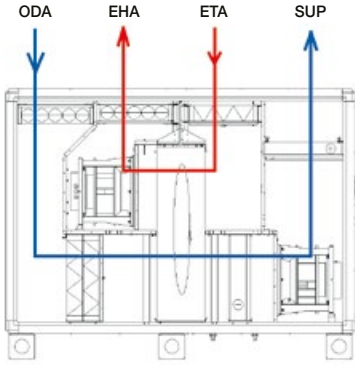

Arrangement diagram of components of Duovent® Compact RV TOP units with mixing (left position „L“)

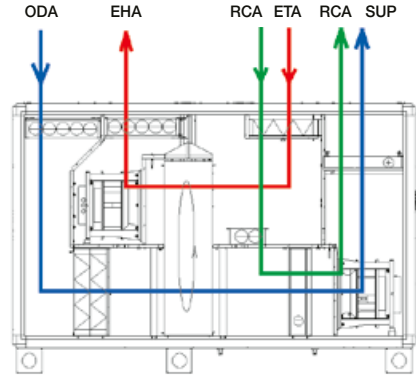

Neck variants – unit vertical arrangement (viewed from operation side):
 Left neck position „L“

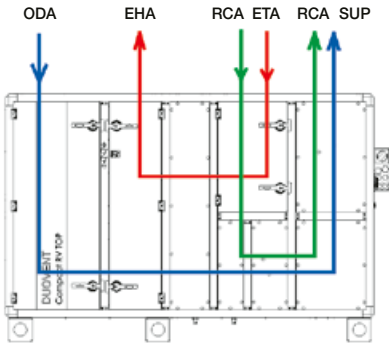

Left neck position „L“

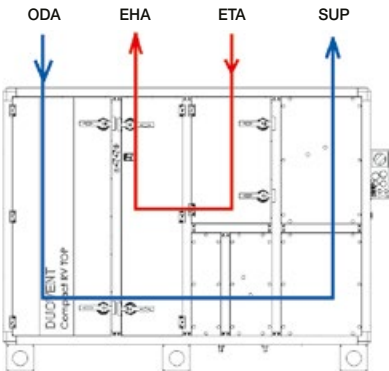

Right neck position „R“

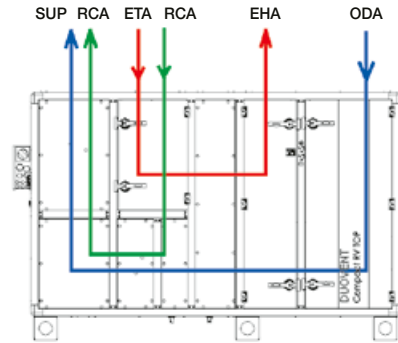

Right neck position „R“

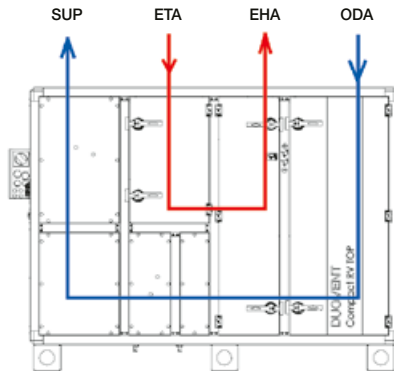

Recuperation

- ODA – suction air
- SUP – supply air
- ETA – exhaust air (out of space)
- EHA – waste air
- RCA – circulation air

Characteristics

Q air flow (m³/h) F7+RV+DCB+DCC ... Output curve with maximum pressure loss of internal components on the supply side (i.e. filter F7 on the supply, regenerator, water heaters 3r., water cooler 4r., droplet eliminator)

Δp_{Σ} unit external static pressure (Pa)

P electric input (W)

η heat recuperation efficiency (%)

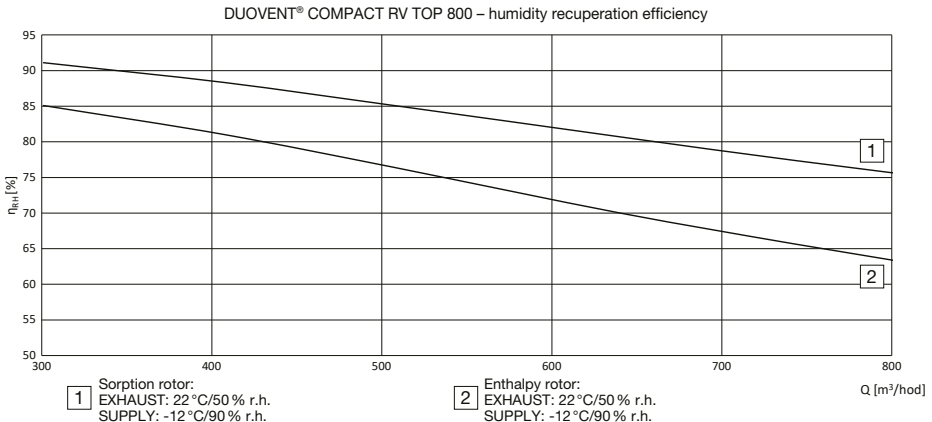
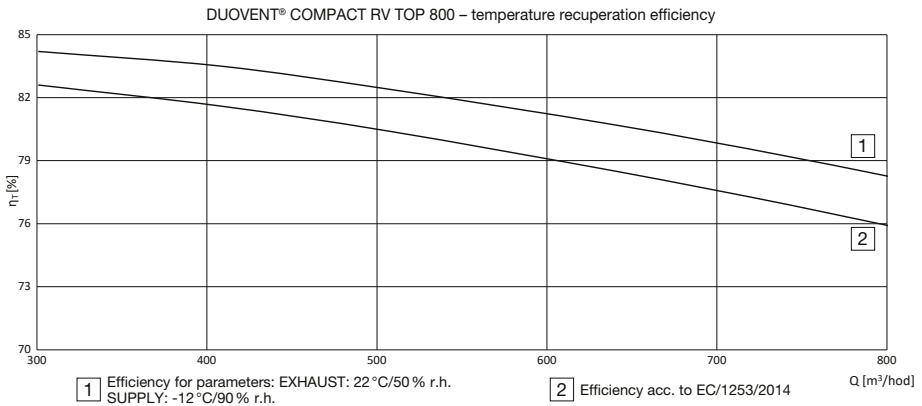
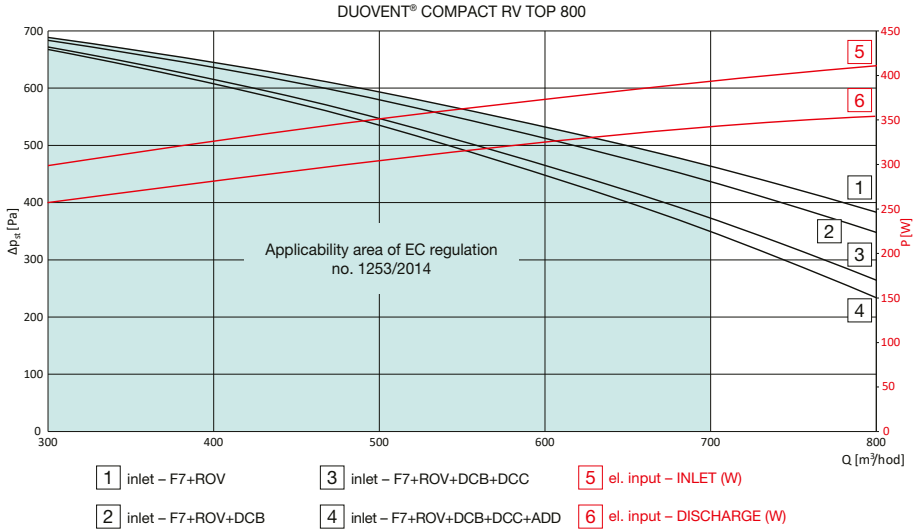

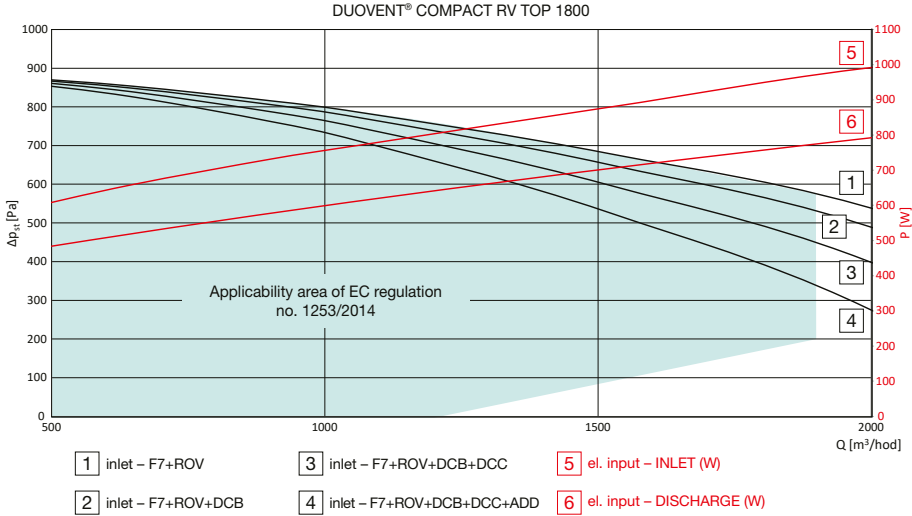

Recuperation

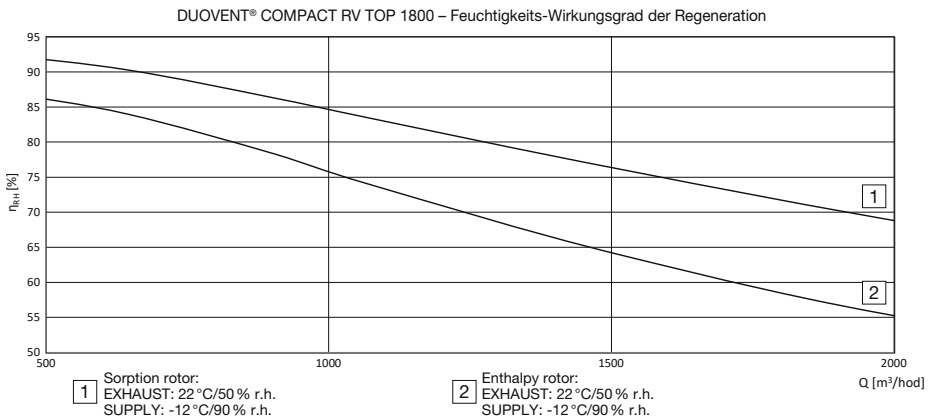
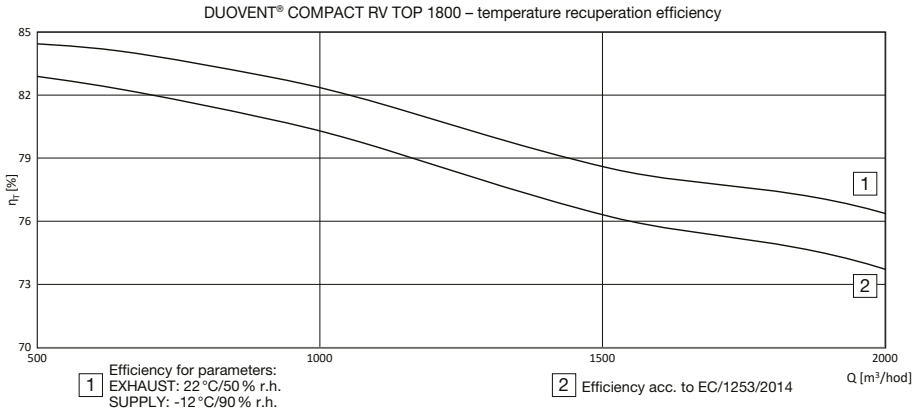

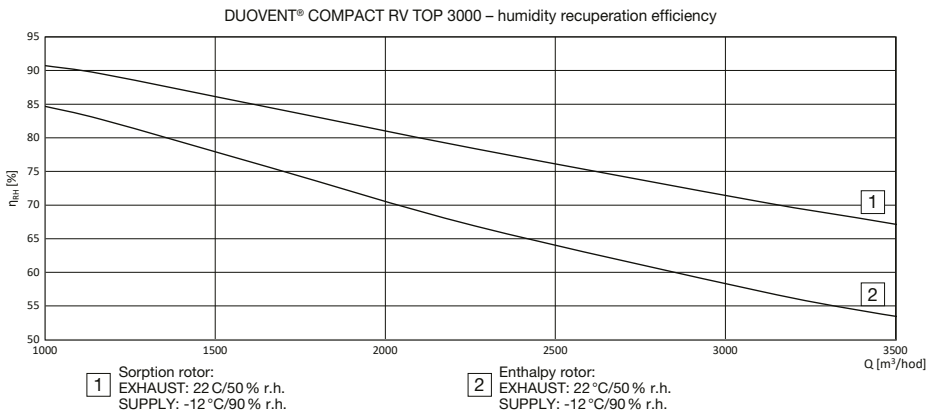
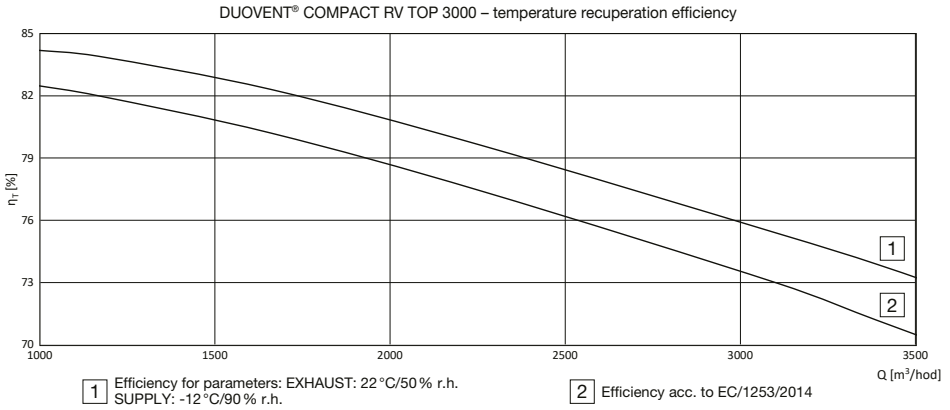
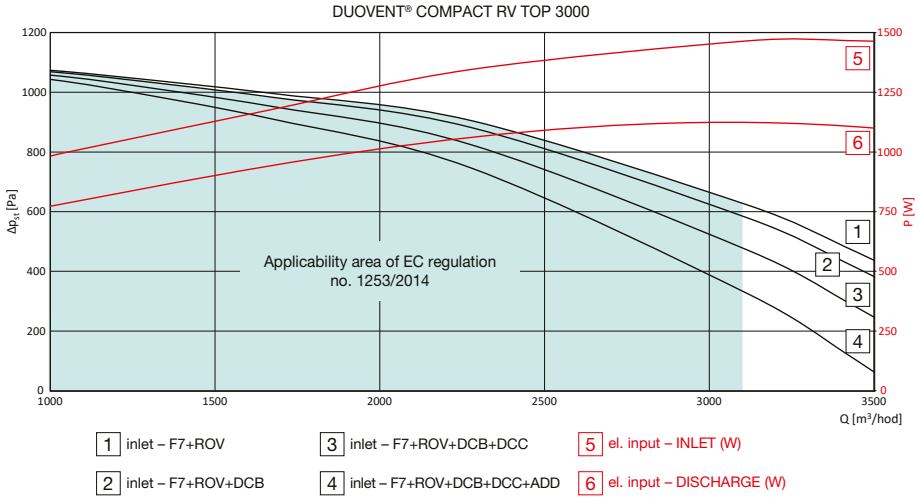

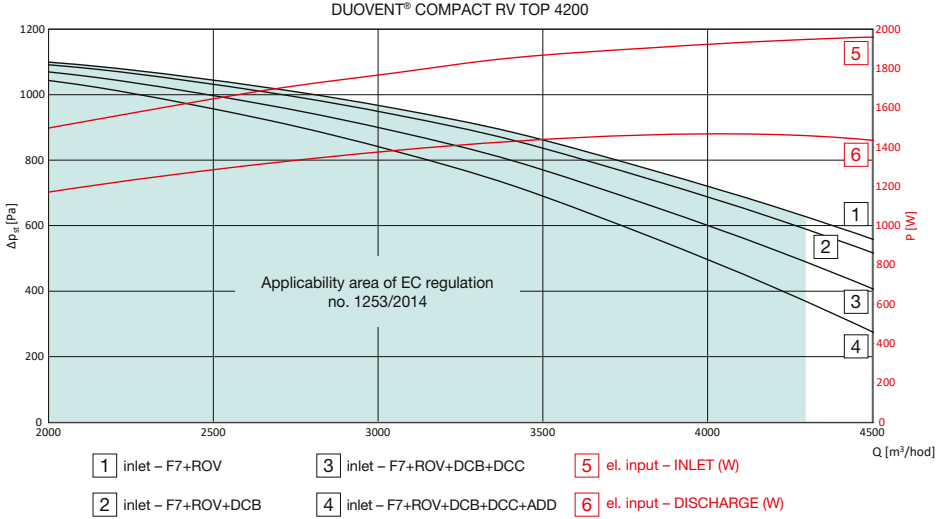

Recuperation

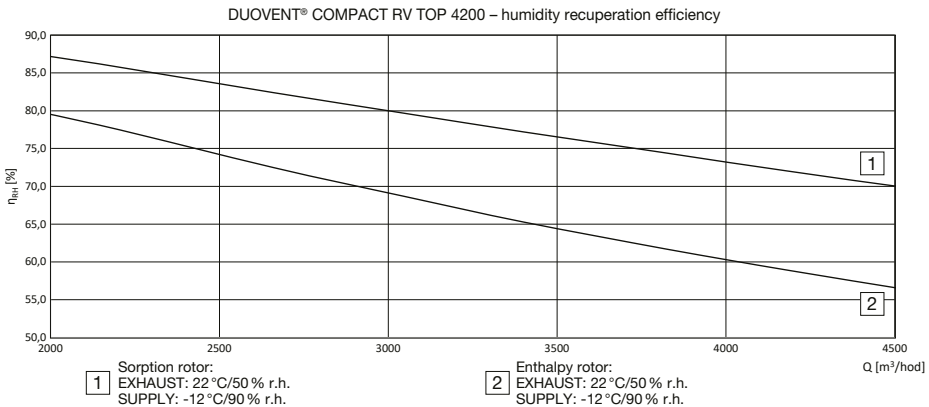
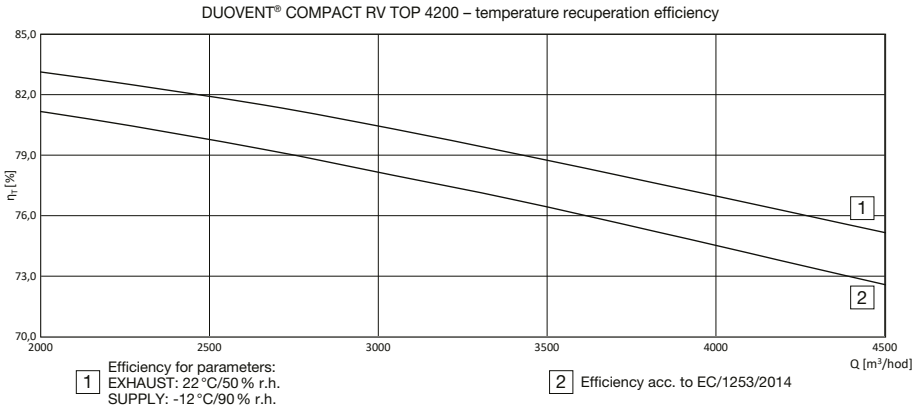

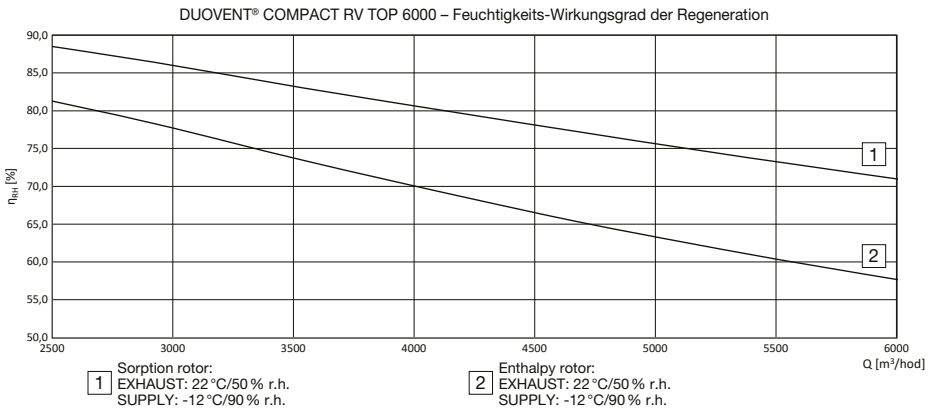
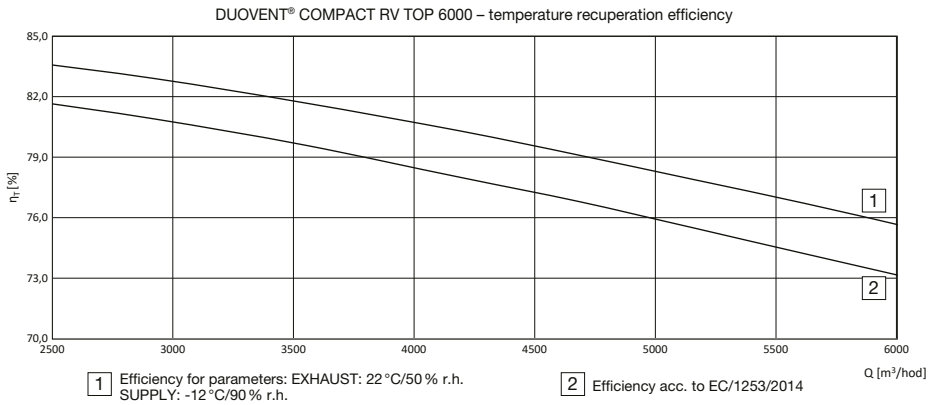
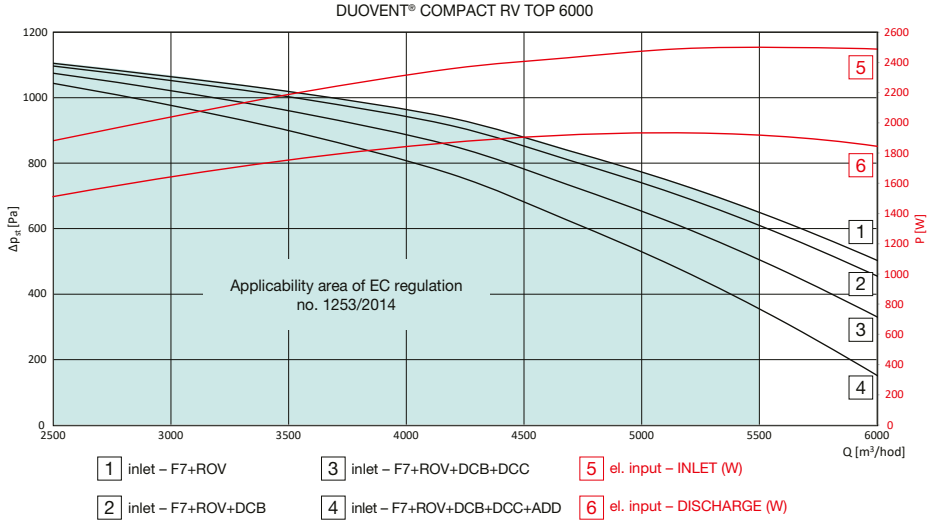

Sound power (pressure) level in octave bands [db(A)]*

DUOVENT® COMPACT RV TOP 800 (for Q = 700m³/h)

Hz	63	125	250	500	1000	2000	4000	8000	L _{WA}
fresh	52	59	67	71	69	63	55	49	75
inlet	51	63	72	75	76	76	67	64	81
L _{WA} exhaust	53	58	66	71	68	62	56	50	74
waste	51	63	71	75	76	76	67	64	81
case**	46	61	67	61	53	47	32	25	69

DUOVENT® COMPACT RV TOP 1800 (for Q = 1900m³/h)

Hz	63	125	250	500	1000	2000	4000	8000	L _{WA}
fresh	45	52	65	67	66	67	59	51	72
inlet	49	59	74	74	80	81	72	68	84
L _{WA} exhaust	44	50	63	67	65	66	59	51	72
waste	47	57	71	71	79	79	72	68	83
case**	43	56	69	59	56	51	37	29	69

DUOVENT® COMPACT RV TOP 3000 (for Q = 3100m³/h)

Hz	63	125	250	500	1000	2000	4000	8000	L _{WA}
fresh	41	49	63	70	69	69	62	55	75
inlet	46	57	72	76	84	83	75	72	87
L _{WA} exhaust	41	49	63	71	69	69	62	56	75
waste	46	56	71	77	83	83	76	72	87
case**	41	54	67	62	60	54	41	33	69

DUOVENT® COMPACT RV TOP 4200 (for Q = 4300m³/h)

Hz	63	125	250	500	1000	2000	4000	8000	L _{WA}
fresh	46	48	68	69	69	68	61	55	75
inlet	51	57	74	76	83	81	73	70	86
L _{WA} exhaust	47	50	67	71	69	68	62	56	75
waste	52	58	74	77	83	81	74	71	86
case**	46	55	69	62	60	52	39	31	70

DUOVENT® COMPACT RV TOP 6000 (for Q = 5500m³/h)

Hz	63	125	250	500	1000	2000	4000	8000	L _{WA}
fresh	41	50	70	70	69	69	61	57	76
inlet	49	59	76	78	83	81	73	71	86
L _{WA} exhaust	41	53	70	72	69	68	62	58	76
waste	49	61	76	80	83	80	74	72	87
case**	44	58	71	65	60	51	39	32	72

* Data for configuration:
 INLET – IN. FL + F7 + RV + DCC + DCB /
 OUTLET – OUT.FL. + M5 + RV
 ** shell damping with De value acc. to EN1886

Recuperation

Characteristics of recuperation units acc. to EC regulation 2009/125/EC, no. 1253/2014:

Size unit	Nominal air flow [m³/h]	SFP _{tot} [W/(m³/s)]	recuperation efficiency [%]	SFP _{tot} LIMIT 2018 [W/(m³/s)]	external pressure [Pa]
800	700	974	77,8	1215	350
1800	1900	1006	73,3	1030	350
3000	3100	956	73,1	974	350
4200	4300	917	73,4	933	350
6000	5500	899	74,6	919	350

Technical data of water heaters DCA (t_w = 80/60 °C) and DCB (t_w = 45/35 °C)

Size unit	temp. gradient [°C]	power [kW]	air flow [m³/h]	air inlet temperature [°C]	air outlet temperature [°C]	pressure loss at water side [kPa]	water flow [m³/h]
800	80/60	4,7	800	12	29,5	2	0,21
	45/35	3,1			23,7	5	0,27
1800	80/60	11,7	1800	12	31,5	5	0,52
	45/35	7,8			24,9	11	0,68
3000	80/60	18,2	3000	12	30,2	4	0,8
	45/35	13,3			25,2	9	1,15
4200	80/60	26,5	4200	12	30,9	6	1,17
	45/35	17,7			24,6	8	1,54
6000	80/60	36,5	6000	12	30,2	5	1,6
	45/35	26,6			25,3	16	2,31

Technical data of water coolers DCC ($t_w = 6/12^\circ\text{C}$) and evaporation units DX ($t_{vp} = 6^\circ\text{C}$, R410A coolant)

Size unit	temp. gradient / evaporation temp. [$^\circ\text{C}$]	power [kW]	air flow [m^3/h]	inlet temperature [$^\circ\text{C}$] rel. humidity [%]	outlet temp. [$^\circ\text{C}$]	pressure loss at water/coolant side [kPa]	water flow [m^3/h]
800	6/12 $^\circ\text{C}$	5,2	800	35 $^\circ\text{C}$ /35%	20	4	0,74
	6	5,8			19,1	75	
1800	6/12 $^\circ\text{C}$	15,4	1800	35 $^\circ\text{C}$ /35%	16,8	16	2,2
	6	14,2			18,7	41	
3000	6/12 $^\circ\text{C}$	23,8	3000	35 $^\circ\text{C}$ /35%	17,7	15	3,4
	6	23,7			17,7	48	
4200	6/12 $^\circ\text{C}$	33,4	4200	35 $^\circ\text{C}$ /35%	17,7	20	4,77
	6	32,7			18	68	
6000	6/12 $^\circ\text{C}$	45	6000	35 $^\circ\text{C}$ /35%	17,5	19	6,42
	6	45			18,5	76	

Technical data of electric heaters (supply power 1x 230V/50Hz for size 800, 3x 400V/50Hz for sizes 1800 to 6000), assignment of control kits:

Größe des Geräts	Typ DI	Leistung [kW]	Anzahl der Sektionen	Set Digireg®
800	IBE-RV-TOP-800-3/1	3	1	M1-E8-2
1800	IBE-RV-TOP-1800-7,5/1	7,5	1	M3-E15
3000	IBE-RV-TOP-3000-15/1	15	1	M3-E15
4200	IBE-RV-TOP-4200-15/1	15	1	M3-E15
6000	IBE-RV-TOP-6000-22/2	22,5	2	M3-E24

Accessories

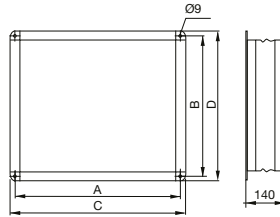

DUO-RV-TOP-IAE

- flexible coupling to connect inlet and outlet necks of HVAC unit with pipe lines
- prevents transfer of vibration to air-ducts
- flange width 20 mm
- to be delivered for unit sizes RV TOP 800–6000

Type	A [mm]	B [mm]	C [mm]	D [mm]
DUO-RV-TOP-IAE-800	500	210	520	230
DUO-RV-TOP-IAE-1800	810	270	830	290
DUO-RV-TOP-IAE-3000	970	320	990	340
DUO-RV-TOP-IAE-4200	1130	400	1150	420
DUO-RV-TOP-IAE-6000	1280	440	1300	460