



# INSTRUCTION MANUAL

[www.elektrodesign.cz](http://www.elektrodesign.cz)

## DUOVENT® COMPACT DV TOP Ventilation unit with heat recuperation

### SALE PRAGUE

Boleslavova 15, 140 00 Prague 4  
tel.: 241 00 10 10-11

### CENTRAL WAREHOUSE

Boleslavská 1420, 250 01 Stará Boleslav  
tel.: 326 90 90 20, 30

## Contents

<b>1. General.....</b>	<b>3</b>
1.1 Introduction.....	3
1.2 Warranty.....	3
1.3 Safety regulations .....	4
<b>2. General.....</b>	<b>4</b>
<b>3. Technical data.....</b>	<b>4</b>
3.1 Manufacturing label .....	4
3.2 Basic dimensions.....	7
3.3 General technical data.....	8
3.4 Operation conditions .....	10
3.5 Declaration of conformity .....	10
<b>4. Transport, storage, acceptance.....</b>	<b>10</b>
<b>5. Installation .....</b>	<b>10</b>
5.1 Place of installation.....	10
5.1.1 Distances from building structures (service space) .....	11
5.1.2 How to store the unit at the destination.....	11
5.2. Installation procedure and connection to HVAC distribution lines .....	12
5.2.1 Safety instructions for installation .....	12
5.2.2 Air connection .....	12
5.2.3 Connection of electric heater.....	15
5.2.4 Connection of water heater.....	16
5.2.5 Connection of water cooler.....	17
5.2.6 Connection of direct evaporator .....	18
5.2.7 Connection of condensate drain.....	18
5.2.8 Bypass and mixing flap.....	20
5.2.9 Inlet and outlet flap .....	21
5.2.10 Basic accessories .....	22
5.2.10.1 Condensate traps.....	22
5.2.10.2 Regulation unit for ESU water heater or ESUCH water cooler .....	23
<b>6. Electrical installation .....</b>	<b>24</b>
6.1 Connection of electric motor fans .....	24
6.2 Connection of electric heater.....	27
6.3 Instrumentation and control system .....	27
6.3.1 Digital regulation system Digireg®.....	27
6.3.2 Temperature control .....	28
6.3.3 Installation .....	28
6.3.4 Technology scheme of Digireg® I&C systems .....	29
6.3.5 Control .....	29
<b>7. Commissioning.....</b>	<b>30</b>
7.1 Installation and connection check .....	30
7.2 Trial operation .....	30
<b>8. Operation and maintenance .....</b>	<b>30</b>
8.1 Safety instructions for operation and maintenance.....	30
8.2 Equipment service .....	30
8.2.1. Replacement and maintenance of filters.....	31
8.2.2. Fan maintenance.....	31
8.2.3. Maintenance of recuperation exchanger .....	32
8.2.4. Periodic inspections.....	32
8.2.5. Spare parts.....	32
<b>9. Decommissioning and recycling.....</b>	<b>32</b>
<b>Annex No. 1 – Information on Commission Regulation (EU) No. 1253/2014 .....</b>	<b>33</b>

## 1. GENERAL

### 1.1 INTRODUCTION

This manual is intended for ventilation units with heat recuperation DUOVENT® COMPACT DV TOP. Its purpose is to provide as much information as possible for the safe installation, commissioning and use of this equipment. Due to the fact that our products are constantly evolving, we reserve the right to change this manual without prior notice.

### 1.2 WARRANTY

We do not guarantee the suitability of the devices for special purposes, the determination of suitability is fully in the competence of the customer and the designer. The warranty for the devices is in accordance with valid legal regulations. The warranty is only valid if all installation and maintenance instructions, including protection, are observed. The warranty covers manufacturing defects, material defects or malfunctions of the device.

**The warranty does not cover defects caused by:**

- improper use and design
- improper handling (does not apply to mechanical damage)
- during transport (compensation for damage caused during transport must be claimed from the carrier)
- incorrect installation, incorrect electrical connection or protection
- incorrect operation
- unprofessional intervention in the device
- disassembling the device
- use in unsuitable conditions or in an unsuitable manner
- wear and tear caused by normal use
- third party intervention
- due to a natural disaster
- frost-damaged water exchanger parts are not covered by the warranty if it has been demonstrably proven that the unit was in operation without heating water at min. design temperature or during shutdown of the boiler circuit

**When claiming the warranty, it is necessary to submit a report containing:**

- data on the complaining company
- date and number of the sales document
- exact specification of the defect
- wiring diagram and fuse details
- measured values when starting the device
  - voltage
  - current
  - air temperature
  - air flow

The warranty repair is carried out in principle at the discretion of ELEKTRODESIGN ventilatory spol. s r.o. at the company's service centre or at the installation site. The method of eliminating the defect is solely at the discretion of the service company ELEKTRODESIGN ventilatory spol. s r.o. The complaining party will receive a written statement on the result of the complaint. In the event of an unjustified complaint, the complaining party pays all costs of its implementation.

#### **Warranty conditions**

The device must be installed by a professional air handling service company. **DUOVENT® COMPACT DV TOP, incl. control system DVAV, DCAV, DCOP, must be commissioned only by the Seller or by the person authorised by the Seller. Failure to comply with this condition will result in the termination of the Buyer's rights from defective performance and from the Quality Warranty. Detailed terms are specified in the Seller's Complaint Procedure.** The electrical connection must be made by a specialist electrical company. Installation and location of the device must be unconditionally performed in accordance with ČSN 33 2000-4-42 (IEC 364-4-42). The device must be subjected to an initial electrical inspection according to ČSN 33 1500. The device must be regulated to the designed air-conditioning parameters. When starting the device, it is necessary to measure the above-specified values and make a record of the measurement, confirmed by the company putting the device into operation. In the event of a complaint about the equipment, it is necessary to submit a record of the above-mentioned parameters from commissioning together with the declaration protocol together with the initial revision, which the operator acquires within the commissioning and maintenance of the electrical installation.

During the operation, it is necessary to perform regular inspections of electrical equipment within the deadlines according to ČSN 33 1500 and inspection, maintenance and cleaning of air-conditioning equipment. It is necessary to keep a „Maintenance and inspection book“ for the maintenance and service of the device, for which the device operator is responsible.

When taking over the device and unpacking it from the transport packaging, the customer is obliged to perform the following inspections. It is necessary to check the integrity of the device, as well as whether the delivered device exactly agrees with the ordered device. It is always necessary to check whether the label and identification data on the transport packaging, equipment or engine correspond to the designed and ordered parameters. Due to the continuous technical development of the equipment and changes in technical parameters reserved by the manufacturer, and the time lag between the project and the implementation of own sales, fundamental differences in the parameters of the equipment at the date of sale cannot be ruled out. The customer is obliged to inform the manufacturer or supplier about such changes before ordering the goods. Subsequent complaints cannot be taken into account.

### 1.3 SAFETY REGULATIONS

Adherence to these instructions should not pose any safety, health or environmental risks in accordance with EC directives (CE marked). The same applies to other products used in the device or during installation. Consider the following warnings:

- Observe the safety instructions to prevent damage to the device or personal injury.
- The technical information in this manual must not be changed.
- It is forbidden to interfere with the motor of the device.
- In order for the device to comply with EC directives, the device must be connected to the mains in accordance with the applicable regulations.
- The device must be installed in such a way that under normal operating conditions it cannot come into contact with any moving part and / or live part.
- The device complies with the applicable regulations for the operation of electrical equipment.
- Always disconnect the device from the power supply before carrying out any work on it.
- Appropriate tools must be used when handling or maintaining the device.
- The device must only be used for the purposes for which it is intended.
- This appliance is not intended for use by children under 8 years of age and persons with reduced physical, sensory or mental capabilities, or lack of experience and knowledge, unless they have been given supervision or instruction concerning use of the appliance by a responsible person. The user must ensure that children do not play with the device. Cleaning and maintenance of the appliance must not be carried out by children without supervision.

## 2. GENERAL

The DUOVENT® COMPACT DV TOP unit is manufactured in accordance with valid Czech and European laws, decrees, standards and technical rules. The unit may only be installed and used in accordance with this documentation. The manufacturer is not liable for damage caused by other uses and the buyer bears all risks. Changes and modifications to the complete product that could affect safety and proper function are prohibited. Installation and operating documentation must be available to the operator and service. It is advisable to place it close to the installed unit.



When disposing of the unit, the relevant environmental and waste disposal regulations must be observed. In the case of final disposal, it is necessary to follow the principles of separate collection. The applicable standards, safety regulations and generally accepted technical rules must be observed during installation, electrical connection, commissioning, repairs and maintenance of the units. Assembly of units, connection of electrical installation, commissioning of the unit, repairs, maintenance and operation may be performed only by a natural or legal person with a valid authorization.

The current version of this manual is available at [www.elektrodesign.cz](http://www.elektrodesign.cz).

## 3. TECHNICAL DATA

### 3.1 MANUFACTURING LABEL AND INFORMATION LABELS

Each unit is provided with a manufacturing label, which contains the basic data needed to identify the device. The label is usually located on the front of the unit or on the connection side of the heat exchanger parts.

			 Protection rating: <input type="text"/>	Made in Czech Republic
PRODUCT TYPE:	<input type="text"/>			
TYPE OF THE UNIT:	<input type="text"/>			
SERIAL NUMBER:	<input type="text"/>	NOMINAL AIR FLOW:	<input type="text"/>	m <sup>3</sup> /h
YEAR:	<input type="text"/>	MAX. EXTERNAL PRESSURE AT MAX. AIR FLOW:	<input type="text"/>	Pa
WEIGHT OF THE UNIT:	<input type="text"/> kg	<u>WATER HEATER</u> TEMPERATURE GRADIENT:	<input type="text"/>	°C
MIN./MAX. OPERATING TEMPERATURE:	<input type="text"/> °C	MAX. WATER TEMPERATURE:	<input type="text"/>	°C
SUPPLY VOLTAGE (Um):	<input type="text"/> <input type="checkbox"/> Hz	MAX. WORKING PRESSURE:	<input type="text"/>	MPa
CURRENT (In):	<input type="text"/> A	<u>WATER COOLER</u> TEMPERATURE GRADIENT:	<input type="text"/>	°C
MAX. EL. POWER OF THE UNIT:	<input type="text"/> W	MAX. WORKING PRESSURE:	<input type="text"/>	MPa
POWER OF ELECTRIC HEATER:	<input type="text"/> W	TYPE OF REFRIGERANT FOR EVAPORATORS:	<input type="text"/>	
<b>MANUFACTURER:</b> ELEKTRODESIGN ventilatory s.r.o., Boleslavova 15, 140 00 PRAGUE 4, CZECH REPUBLIC				

Key to distinguish the variants of DUOVENT® Compact DV TOP recuperation units („TYPE“ field on the label):

D	U	O	V	E	N	T	C	O	M	P	A	C	T	D	V	3	6	0	0	D	I	D	X	M	X	K	L	F	7	/	M	5	D	V	A	V	P	T	O	P	S	P
															1	2	3	4	5	6	7	8	9											10								

1 – unit size – 500, 1000, 1500, 2200, 3600, 5100, 6000, 7800

2 – heater type:

**DI** - electric

**DCA** – water for gradient on water 80 / 60 °C

**DCB** – water for water drop 45 / 35 °C

3 – water cooler type:

**DCC** – water for gradient on water 6 / 12 °C

**DX** – direct evaporator for refrigerant R410A, evaporating temperature 6 °C

(for a direct evaporator, it is always necessary to specify the type of refrigerant, the required capacity and the division of the refrigeration capacity into sections according to the type of condensing unit used).

For evaporation units used for reverse operation with the thermal pump this fact must be specified in the order.

**DXr** – evaporator in connection for reversible operation (cooling/heating), refrigerant R410A.

If it is a unit with DXr and bivalent reheating, positions „2“ and „3“ must be turned.

4 – **MX** – mixing damper with preparation for mounting the actuator

**C** – mixing flap enabling 100 % air circulation with preparation for mounting the actuator

5 – **KL** – inlet and outlet damper with preparation for mounting the actuator (if the unit is equipped with the I&C system, the actuator is included)

6 – Filtering class of fresh air / exhaust air filter (G4-F9)

7 – control system type

**D** – Digireg®

8 – air flow control type

**VAV** – variable air flow

**CAV** – constant air flow

**COP** – constant static pressure supplied to the HVAC piping network

9 – position of the sockets with respect to the operating side - according to the table of socket variants (**P, PB, PBP, PBO, L, LB, LBP, LBO**).

For sizes 500 and 1000, only the position of the **L** or **P** sockets is possible.

10 – **SP** – design of the unit for ventilation of pool halls

**Order examples**

DUOVENT® COMPACT DV 3600 DI DX MX KL F7/M5 DVAV P TOP

Unit size 3600 with electric heater, direct evaporator, bypass and mixing damper, integrated dampers for suction and exhaust, filtration on inlet F7, single-stage filtration on outlet M5, I&C system Digireg with VAV, position P.

In addition, the unit is equipped with **labels to identify the internal arrangement of functions:**



WATER / ELECTRIC HEATER



FAN



WATER / DIRECT COOLER



FILTER

Die Einheit ist auch mit Hinweisschildern ausgestattet:



HEATING/COOLING MEDIA INPUT



HEATING/COOLING MEDIA OUTPUT

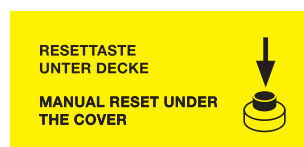

NOTICE ON LOCATION OF FAULT RESET BUTTON OF EL. HEATER

KONDENSAT ABLAUF  
 CONDENSATE DRAIN



NOTICE ON LOCATION OF THE CONDENSATE DRAINAGE NECK IN THE BOTTOM OF THE UNIT



### IMPORTANT WARNING

It is necessary for warranty recognition, to connect built-in thermal protection of the electric motor (see instruction manual ELEKTRODESIGN VENTILATORY).

[www.elektrodesign.cz](http://www.elektrodesign.cz)

NOTICE ON CONNECTION OF FAN MOTOR PROTECTIONS

### IMPORTANT NOTICE!!

sensor located below the thermal insulation

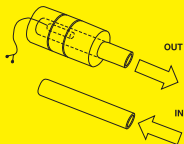

**CAUTION!**  
Correct function of the water exchanger anti-freeze protection requires proper insulation of the protecting contact temperature sensor at the water circuit return line as closest to the water exchanger outlet as possible to prevent influencing of the decisive temperature by the environment temperature.

**BEFORE START OF THE UNIT, THE SYSTEM MUST BE VENTED. THE VENTING SCREWS ARE LOCATED INSIDE OR OUTSIDE THE UNIT AT THE WATER EXCHANGER MANIFOLD.**

WARNING OF THE NECESSITY OF INSULATION OF THE ANTIFREEZE PROTECTION CONTACT SENSOR



### WARNING

Do not start and/or use the unit during constructions works (drilling, grinding etc.). There is a risk of unrepairable damage of the unit and distribution lines! The unit must be commissioned by an authorized person only!

If these instructions are violated, the manufacturer has no responsibility for any subsequent losses and the warranty for the HVAC unit becomes void!

WARNING - DO NOT OPERATE THE UNIT WHILE CONSTRUCTION WORK IN PROGRESS

### Air flow measurement

$$V = K \cdot \sqrt{\Delta p}$$

$$\Delta p \text{ (Pa)}$$

$$V \text{ (m}^3\text{/h)}$$

Fan type	K (-)
RH25V, R3G250, RH25C	60
K3G250	76
RH31C	95
R3G310	116
RH35C	121
RH40C	154
RH45C	197

AIR FLOW CALCULATION PLATE LOCATED AT FAN SUCTION PRESSURE ORIFICE PORT



**BEWARE!**  
**ELECTRIC**  
**APPLIANCE**



**DON'T OPEN**  
**THE DOOR**  
**DURING**  
**OPERATION**

WARNING LABELS

**MAIN SWITCH**

Labels to identify the type of air stream:

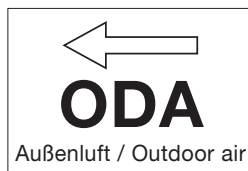

### 3.2 BASIC DIMENSIONS OF DUOVENT® COMPACT DV TOP UNITS

Dimensional diagram of DUOVENT® 500,1000 TOP units

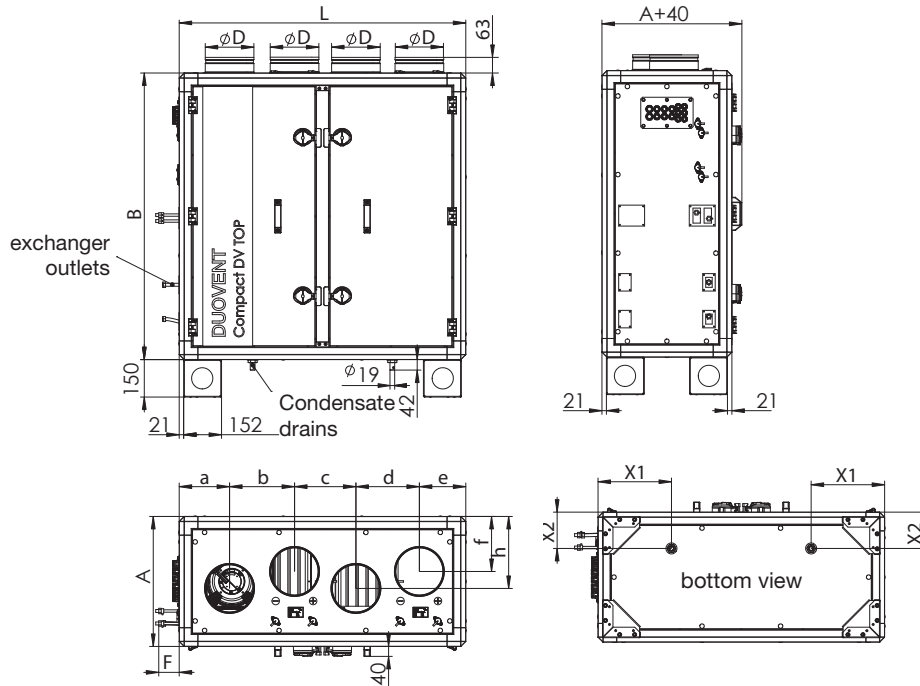

Type	A [mm]	B [mm]	L [mm]	Ø D [mm]	F [mm]	a [mm]	b [mm]	c [mm]	d [mm]	e [mm]	f [mm]	h [mm]	X1 [mm]	X2 [mm]
DV 500 TOP	521	1149	1149	200	51	202	260,5	246	240,5	254,5	220,5	288,5	320	150
DV 1000 TOP	678	1149	1306	250	51	207	303	297	292	207	246	404	255	180

DUOVENT® COMPACT DV 1500 to 3600 TOP units

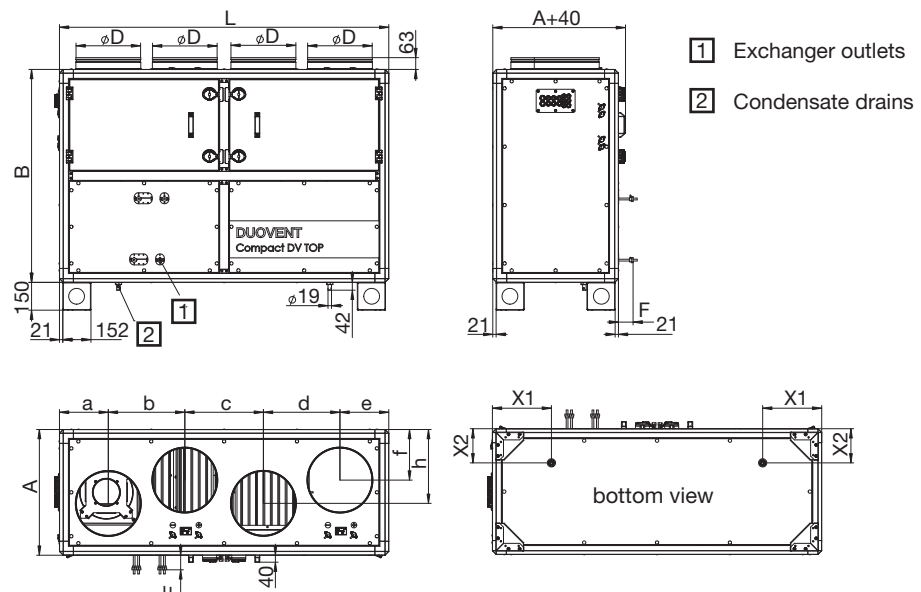

Type	A [mm]	B [mm]	L [mm]	Ø D [mm]	F [mm]	a [mm]	b [mm]	c [mm]	d [mm]	e [mm]	f [mm]	h [mm]	X1 [mm]	X2 [mm]
DV 1500 TOP	678	1149	1777	355	51	263,5	413	424	413	263,5	273	398,5	315	180
DV 2200 TOP	835	1463	1934	400	51	292	447	498	452	287	321,5	521,5	290	180
DV 3600 TOP	992	1620	2091	450	51	307,5	480,5	515	480,5	307,5	351	641	290	180

DUOVENT® COMPACT DV 5100 to 7800 TOP units

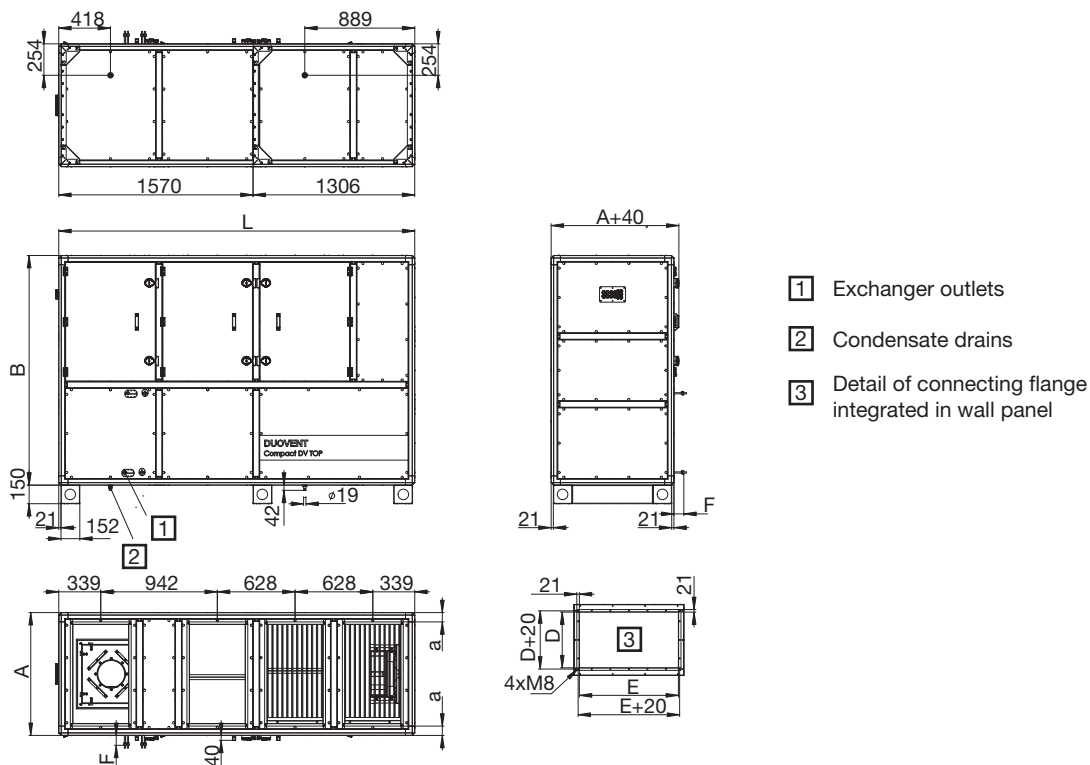

Type	A [mm]	B [mm]	L [mm]	D [mm]	E [mm]	F [mm]	a [mm]
DV 5100 TOP	992	1777	2876	450	800	51	96
DV 6000 TOP	1149	1777	2876	450	950	51	99,5
DV 7800 TOP	1463	1777	2876	450	1250	51	106,5

### 3.3 GENERAL TECHNICAL DATA

Detailed technical data of the specific design of the DUOVENT® unit are part of the technical specification of the unit, which is shipped together with the unit. The technical specification is located in the packaging on the inside or outside of the service door of the unit.

The technical specifications include:

- Investor details
- Information on the installation company (or designer)
- Detailed technical data of all components of the unit (fan, recuperator, heater, cooler, filter)
- Overall dimensions of the unit and the total weight of the unit, including accessories
- Dimensional diagram of the unit, including a representation of the service space
- Specification of I&C scope, if it is part of the delivery
- Description of scope of atypical unit variant



Type	nominal flow [m³/h]	voltage [V/Hz]	inlet/exhaust fan		heater		cooler power* [kW]	efficiency* [%]	unit max. air flow [m³/h]	control system Digireg®	weight** [kg]
			max. input power [W]	current [A]	power* [kW]	current [A]					
500 D	500	1× 230V 50Hz	145/120	0,6/0,5	-	-	-	88	560	M3-Vx	110-122
500 DCA					3,6	-	-				
500 DCB					2,4	-	-				
500 DCC					-	-	3,6				
500 DX					-	-	3,5				
500 DI					2	8,7	-				
1000 D	1000	1× 230V 50Hz	312/260	1,4/1,1	-	-	-	86,8	1200	M3-Vx	148-165
1000 DCA					6,4	-	-				
1000 DCB					4,3	-	-				
1000 DCC					-	-	7,1				
1000 DX					-	-	4,5				
1000 DI					4	17,4	-				
1500 D	1500	3× 400V 50Hz	560/480	2,4/2,1	-	-	-	87,7	1800	M3-Vx	168-190
1500 DCA					10	-	-				
1500 DCB					7,8	-	-				
1500 DCC					-	-	11,1				
1500 DX					-	-	10,5				
1500 DI					4,5	6,5	-				
2200 D	2200	3× 400V 50Hz	715/575	1/0,8	-	-	-	89	2600	M3-Vx	328-355
2200 DCA					16	-	-				
2200 DCB					11,4	-	-				
2200 DCC					-	-	16,9				
2200 DX					-	-	15,6				
2200 DI					9	13	-				
3600 D	3600	3× 400V 50Hz	1253/1098	1,8/1,6	-	-	-	88,5	4200	M3-Vx	365-399
3600 DCA					23,7	-	-				
3600 DCB					17,5	-	-				
3600 DCC					-	-	27,1				
3600 DX					-	-	25,4				
3600 DI					13,5	19,5	-				
5100 D	5100	3× 400V 50Hz	1886/1570	2,7/2,3	-	-	-	90,5	5600	M3-Vx	528-581
5100 DCA					34,3	-	-				
5100 DCB					25,1	-	-				
5100 DCC					-	-	37,3				
5100 DX					-	-	34,8				
5100 DI					22,5	33	-				
6000 D	5900	3× 400V 50Hz	2194/1880	3,2/2,7	-	-	-	90,5	6300	M3-Vx	603-661
6000 DCA					42	-	-				
6000 DCB					29,2	-	-				
6000 DCC					-	-	44,9				
6000 DX					-	-	40,7				
6000 DI					22,5	33	-				
7800 D	7400	3× 400V 50Hz	2692/2335	3,9/3,4	-	-	-	90,8	8200	M3-Vx	698-774
7800 DCA					49,4	-	-				
7800 DCB					38,4	-	-				
7800 DCC					-	-	57				
7800 DX					-	-	53,7				
7800 DI					30	43,5	-				

\* at nominal air flow,  $t_e = -12\text{ °C}/90\text{ \% r.h.}$ ,  $t_i = 22\text{ °C}/50\text{ \% r.h.}$ ,  $t_e = 35\text{ °C}/35\text{ \% r.h.}$  (SUMMER)

\*\* depending on particular variant

Water cooler power DCC for  $t_e = 35\text{ °C}/35\text{ \% r.h.}$ ,  $t_w = 6/12\text{ °C}$ . Water heater power DCA for  $t_e = 10\text{ °C}$ ,  $t_w = 80/60\text{ °C}$ .

Water heater power DCB for  $t_e = 10\text{ °C}$ ,  $t_w = 45/35\text{ °C}$ . Direct evaporating unit power DX for R410A coolant,  $t_e = 35\text{ °C}/35\text{ \% r.h.}$ ,  $t_{off} = 6\text{ °C}$ .

### 3.4. OPERATION CONDITIONS

The unit can be used in rooms normal according to IEC 60364-5-51, resp. ČSN 332000-5-51 ed. 3, ČSN 332000-1 ed.2. The ambient temperature must be between -20 and +40 °C.

The unit can transport air without solid, fibrous, sticky, aggressive chemical and explosive additives. The maximum permissible supply air temperature must not exceed +40 °C. The maximum humidity of the air flowing through the unit is 17 g / kg s.v. (84 % r.h. at 25 °C).

If, due to the immediate climatic conditions, the humidity of the outdoor intake air reaches 100 % r.h. (wet steam), it is at the operator's discretion whether to keep the unit running with the risk of temporary separation of moisture on the internal parts of the unit (eg filters, flaps,...). This humidity cannot be the subject of a complaint.



**CAUTION!**

For units with a direct evaporator (marked DX and DXr in the unit code), **the design air flow through the unit must be observed** when operating the direct evaporator/condenser. It is acceptable to reduce the flow in cooling and heating mode by a maximum of 20 % of the design air flow. For proper operation of the direct evaporator, it is necessary to observe the necessary heat or cold consumption from the heat exchange surface of the evaporator/condenser. If the design amount of energy is not consumed, the condensing unit / heat pump may report a fault in the pressure protections (LP, HP) of the cooling circuit and the condensing unit / heat pump may cycle in ON/OFF mode.



**CAUTION!**

Units with direct evaporator (marked DX and DXr in the unit code) must be equipped with a mixing flap (marked MX in the unit code), which ensures, if necessary, min. condenser/evaporator inlet temperature of +10 °C.

### 3.5. DECLARATION OF CONFORMITY

This product type has been tested by the authorised person no. 227, Výzkumný ústav pozemních staveb – Certifikační společnost s.r.o., Pražská 16, 102 21 Praha 10 Hostivař, and a certificate has been issued to it. For a unit of the above type is issued a „Declaration of Conformity“ within the meaning of Act No. 22/1997 Coll. as amended.

## 4. TRANSPORT, STORAGE, ACCEPTANCE

On the loading surface of the vehicle, the unit must be sufficiently secured against slipping and tipping over. The unit is wrapped in PE foil and placed on transport the pallet. The unit is fixed to the transport pallet by means of textile or plastic tie-ups.



**CAUTION!**

The holes in the frame and legs are not intended for the unit hinging.

During loading and unloading by the fork-lift the unit must be lifted suspended on the transport pallet. When transporting the unit supplied without the transport pallet it is necessary to support the unit on the underside over the entire surface to prevent damage and **to pay attention to the condensate outlet opening on the underside of the unit**. During lifting by a crane, it is necessary to pass the ropes through the transport pallet or under the unit to prevent their slipping. **THE UNIT CAN BE HANDLED ONLY BY SUPPORTING OR TYING UNDER THE UNIT FLOOR - THE UNIT CANNOT BE LIFTED BY THE CEILING OF THE UNIT OR OTHER PARTS (SUCH AS PNEUMATIC FLANGES, EXCHANGER OUTLETS ETC.)** Ensure proper balancing of the transported unit. The ropes above the unit must be stretched to prevent damage.



**CAUTION!**

The unit shall not be transported above persons!

The units must be stored in dry and dust-free areas where the ambient temperature does not fall below + 5 °C. The unit must be protected during storage against mechanical damage, dirt and corrosion caused by permanent condensation of water vapour on the surface of the unit. During storage, it is necessary to protect the units against snow, rain and other weather conditions (store in a covered warehouse).

When accepting the unit, it is necessary to check whether the product was delivered in the agreed design and extent, whether it was not damaged during transport, whether there is no condensed water under the plastic wrap (if there is moisture under the packaging, unpack the unit and dry in a covered dry place) . In case of damage during transport, the transferee must record the extent of damage in the Delivery Note, obtain and send photo documentation to ELEKTRODESIGN ventilátory, s.r.o. Failure to comply with this procedure exposes the transferee to the risk of rejection of the complaint by ELEKTRODESIGN ventilátory, s.r.o.

## 5. INSTALLATION

The unit can only be installed by a professional installation company authorized in accordance with the Trade Licensing Act.

### 5.1 PLACE OF INSTALLATION

The unit can only be installed in accordance with the „Environmental Protocol“, in which the characteristics of all devices that can be placed in this space are clearly defined, and it is not possible to place devices that would affect these conditions in any way. The unit has a limited load

capacity and is certainly not intended for storing and depositing any materials, especially objects of considerable weight. This could deform the housing of the unit or severely damage it. These damages are not covered by the warranty. After connecting the unit to the HVAC piping, it is necessary to check the insulation of the HVAC piping in parts with a risk of condensation. Condensate formed in the air duct can, in unfavourable conditions, spill into the interior of the unit, where it is not separated and may flow out of the unit. The result of this process can be damage to adjacent building structures.

### 5.1.1 DISTANCES FROM BUILDING STRUCTURES (SERVICE SPACE)

Observe the minimum recommended distances from all obstacles to ensure easy maintenance and operation of the unit. If the unit is fitted with Digireg® regulation system, it is necessary to ensure free space from the system distribution box of at least 800 mm and the space for free opening of the doors. It is also necessary to ensure distances on the side of connecting the air duct to the unit. All media and I&C connections, or other constructions, must not prevent the full opening of all openings (doors) used for operation and maintenance of the unit.

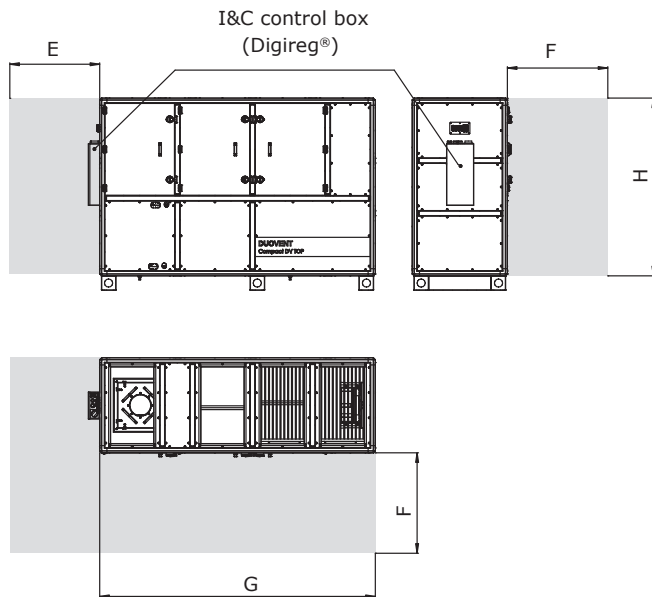

Size	E [mm]	F [mm]	G [mm]	H [mm]
500	940	570	1250	1150
1000	940	700	1350	1150
1500	940	900	1800	1150
2200	940	1000	1950	1470
3600	940	1050	2100	1620
5100	940	1050	2880	1860
6000	940	1200	2880	1860
7800	940	1600	2880	1860

Unless otherwise agreed in the order, the control system distribution box will be placed in the position according to the above figures. The atypical location of the switchboard must be specified in the order. There must be free access to the distribution box; the quality of access must not be impaired by small or protruding objects in the way, slippery floors, etc. The distribution box must not be surrounded in such a way as to impair the transfer of heat to the surrounding area. It is allowed to store and store objects in the vicinity of the distribution box, a minimum space to remain free must be marked. It is not allowed to place any objects on the distribution box.

### 5.1.2 HOW TO STORE THE UNIT AT THE DESTINATION

The unit is designed for floor mounting in a vertical position. The unit must be placed on a solid base with a maximum limit deviation of 3 mm per 2 m of length. The unit must be supported by an anti-vibration rubber pad with a minimum hardness of 50 °Sha. The pad serves to reduce the transmission of the dynamic effects of the unit to the substrate and at the same time to reduce the noise emissions emitted by the vibrating parts of the unit. Washers are not included with the unit.

The unit must be positioned in the slope of max. 1° to the condensate drains at the operation side. Minimum distance of the unit rear wall from the structures is 100 mm.

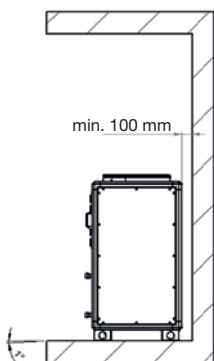

## 5.2 INSTALLATION PROCEDURE AND CONNECTION TO HVAC DISTRIBUTION LINES

All required dimensions and weights of the unit and accessories can be found in the „Technical data“ chapter.

### 5.2.1 SAFETY INSTRUCTIONS FOR INSTALLATION

Follow all safety recommendations to prevent damage to the unit or personal injury. The technical characteristics of this manual must not be changed. The motors of the unit must not be changed. The unit can be connected to a three-phase AC mains supply 400 V / 50 Hz or single-phase 230 V / 50 Hz AC networks according to the specific design of the unit. For installation in accordance with EC regulations, DUOVENT® Compact DV TOP units may only be connected to the mains in accordance with the applicable regulations. The device must be installed in such a way that, under normal operating conditions, it cannot come into contact with any moving or live part. DUOVENT® Compact DV TOP units comply with the applicable regulations for electrical equipment. Before carrying out any work on the device, always disconnect the device from the power supply and secure the main switch of the power supply. energy against being switched on again during service work! Always use the appropriate tools. Use the device only for its intended purpose.

### 5.2.2 CONNECTION TO AIR DISTRIBUTION LINES

Before connecting, check the markings and directions of the air flow in the unit - see following picture.

Size DV 500, 1000 TOP (P position displayed):

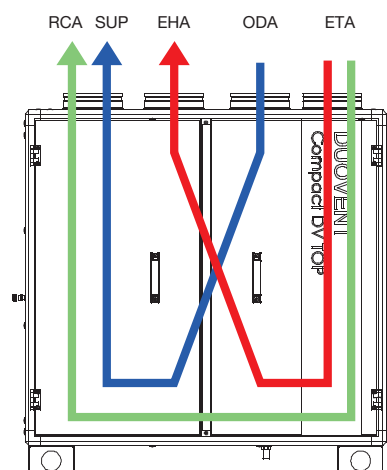

SUP – supply  
ODA – suction  
ETA – exhaust  
EHA – waste  
RCA – circulation

Size DV 1500, 2200, 3600 TOP (P position displayed):

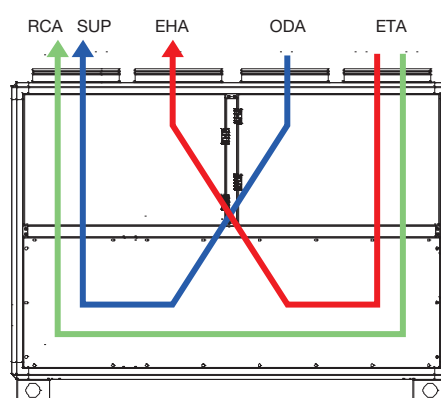

Size DV 5100, 6000, 7800 TOP (P position displayed):

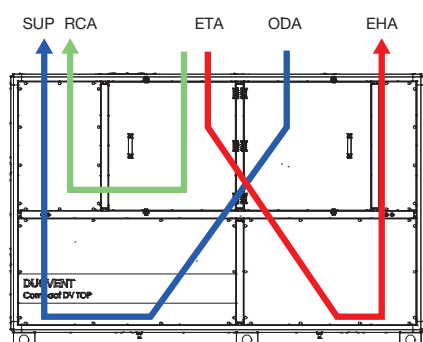

Always follow the markings and directions of airflows that are marked on the stickers on the outer casing of the unit.

The unit must be connected to the piping via flexible sleeves to prevent the transmission of vibrations to the air distribution systems. The flexible sleeves must be bridged by a flexible conductive connection for the discharge of static electricity from the device. In case the flexible sleeves are secured by distance elements against damage during transport and storage, these can be removed only after the attachment of both flanges, on the one hand to the unit and on the other to the air distribution systems.

Possible variants and positions of inlet and outlet ports with respect to the position of the exchanger connection pipes:

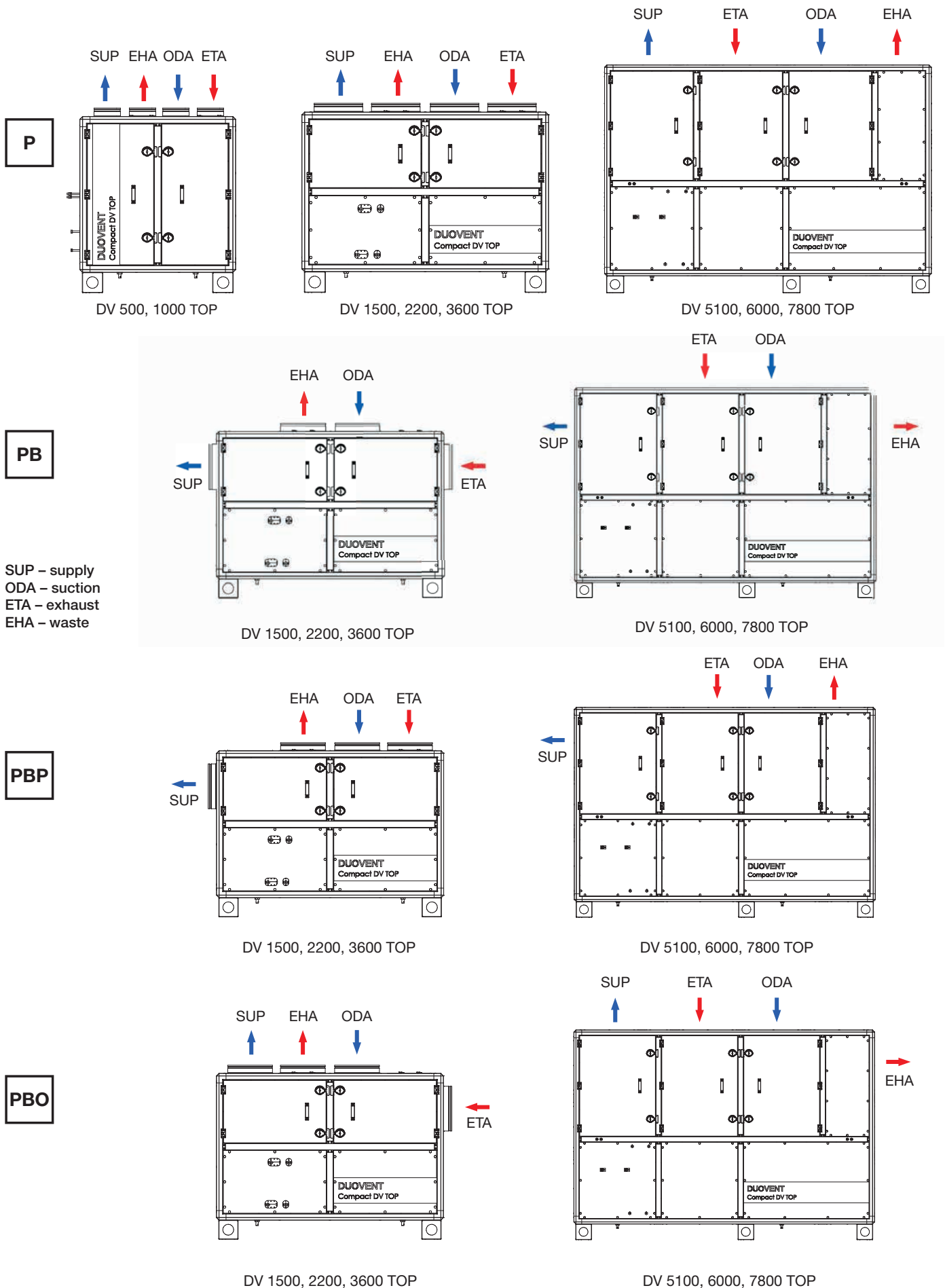

# DUOVENT® COMPACT DV TOP

**L**

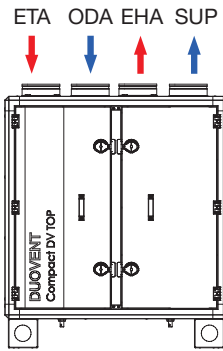

DV 500, 1000 TOP

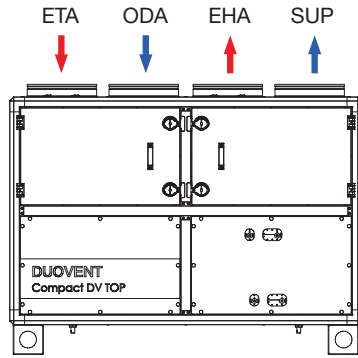

DV 1500, 2200, 3600 TOP

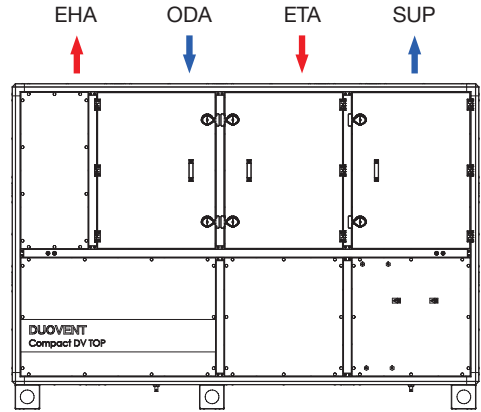

DV 5100, 6000, 7800 TOP

**LB**

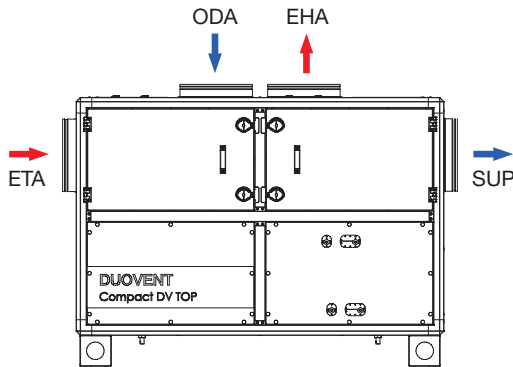

DV 1500, 2200, 3600 TOP

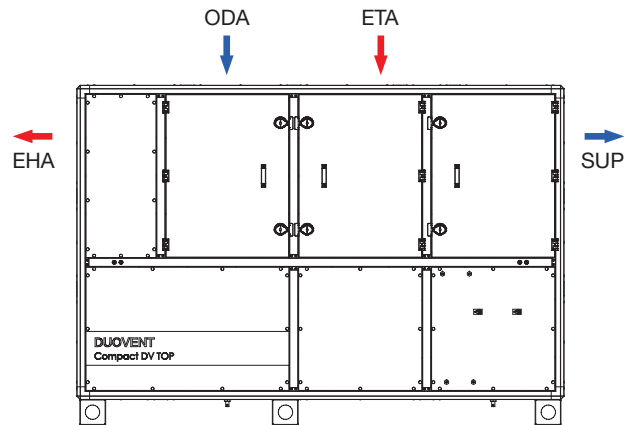

DV 5100, 6000, 7800 TOP

SUP – supply  
ODA – suction  
ETA – exhaust  
EHA – waste

**LBP**

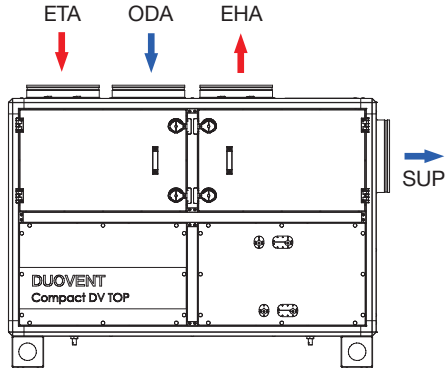

DV 1500, 2200, 3600 TOP

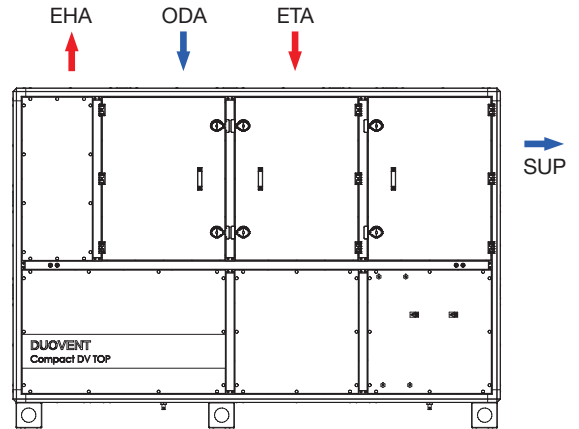

DV 5100, 6000, 7800 TOP

**LBO**

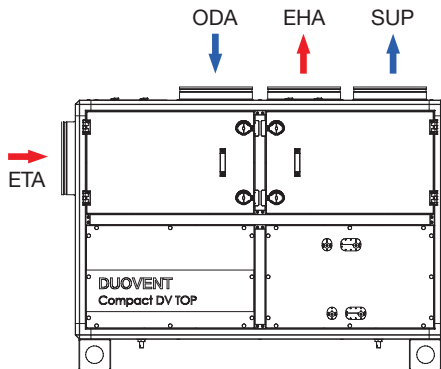

DV 1500, 2200, 3600 TOP

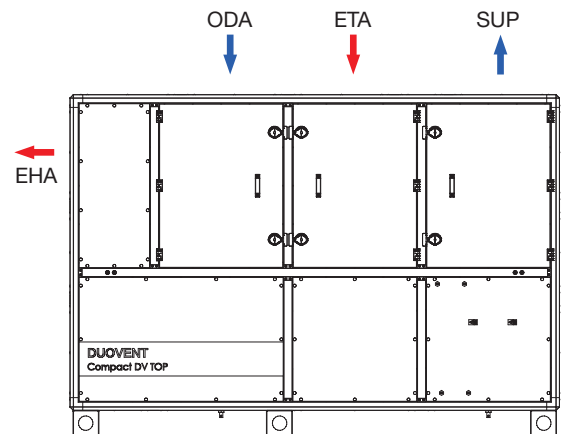

DV 5100, 6000, 7800 TOP

Installation examples of DUOVENT® Compact DV TOP units:

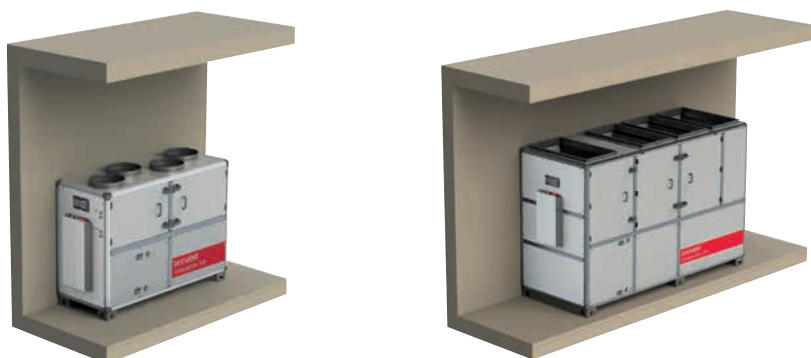

### 5.2.3 ELECTRIC HEATER CONNECTION (MARKED „DI“ IN UNIT CODE)

The unit equipped with an electric DI heater is connected to the relevant control system and further to the electrical network. The general safety regulations for the assembly and installation of electrical equipment apply to this equipment. On the front of the unit there is a cover with a release button for the non-automatic thermal fuse. The non-automatic thermal fuse reacts in the event of overheating of the heater's heating block (temperature above + 120°C). The electric heater is also equipped with an operating thermostat with automatic reset (set temperature is + 60 °C, when it is exceeded, the operating thermostat opens and switches off the heater, after cooling below +60°C the heater automatically switches on again).

**Location of the release button under the cover on the outer casing of the operating side of the unit:**

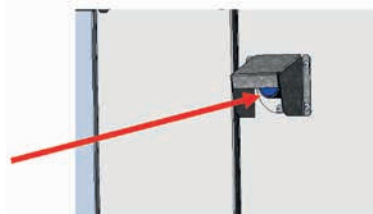

If the electric heater emergency thermostat of the unit trips again, it is necessary to immediately look for the cause of the fault. Repeated manual reset of the heater overheating error by a button on the heater is inadmissible and is not a solution to the fault. The reason for this type of failure may be insufficient air flow through the electric heater of the unit, which will cause the heating rods to overheat and the intervention of the emergency thermostat. The solution is to increase the air flow to the required minimum level according to the following table.

Table of minimum air flows through the electric heater of Duovent® Compact DV TOP units:

Size unit	Minimum air flow (m³/h)
DV 500 TOP	400
DV 1000 TOP	580
DV 1500 TOP	680
DV 2200 TOP	1300
DV 3600 TOP	1700
DV 5100 TOP	2500
DV 6000 TOP	2700
DV 7800 TOP	3600



**CAUTION!**  
It is forbidden to remove, bypass or disconnect safety devices, safety functions and protective devices! Any intervention in the internal connection of the heater is forbidden!



**CAUTION!**  
before service works!  

- The unit must be disconnected from the power supply
- The fan impellers shall not rotate
- Electric heater bars must be cooled to min. 30 °C
- The unit service switch is locked in OFF position

During maintenance, it is necessary to check the tightening of the terminals, clean the space of the heater terminal block from dust and dirt, monitor whether some components show signs of excessive warming, water leakage, mechanical or other damage. Increased attention must be paid to safety circuits, especially the thermal protection of the heater, including the correct response of the control system or power supply switchboard. Faults found must be rectified immediately. These inspections are carried out at least once a year (or more often according to local conditions) by an authorized professional service company.

Example of connection of the two section electric heater terminal block:

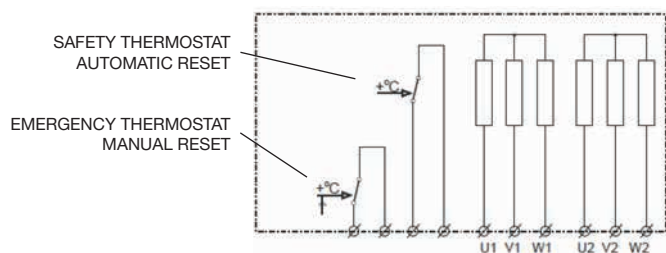

Connection terminal block is accessible after removal of the heater front cover.

### 5.2.4 WATER HEATER CONNECTION

The unit fitted with the water heater (unit code DCA or DCB) is connected to the heating media by means of three-way mixing unit (see „Types of ESU control units“). The water heater outlets are located on the front of the unit and are threaded. The exchanger must be connected in counter-current to the flow of air passing through (in concurrent connection, the exchanger loses approx. 25 % of its output). When tightening the heat exchanger connections, it is necessary, for example, to hold the heat exchanger neck with a second wrench so that the tightening torque is not transmitted to the heat exchanger body.

Table of dimensions of water cooler connection necks:

Unit size	heater/cooler type	thread
500	IBW-A DUOVENT® 500 DC (80/60)	G1/2"
	IBW-B DUOVENT® 500 DC (45/35)	G1/2"
1000	IBW-A DUOVENT® 1000 DC (80/60)	G1/2"
	IBW-B DUOVENT® 1000 DC (45/35)	G1/2"
1500	IBW-A DUOVENT® 1500 DC (80/60)	G1/2"
	IBW-B DUOVENT® 1500 DC (45/35)	G1/2"
2200	IBW-A DUOVENT® 2200 DC (80/60)	G3/4"
	IBW-B DUOVENT® 2200 DC (45/35)	G3/4"
3600	IBW-A DUOVENT® 3600 DC (80/60)	G1"
	IBW-B DUOVENT® 3600 DC (45/35)	G1"
5100	IBW-A DUOVENT® 5100 DC (80/60)	G1.1/4"
	IBW-B DUOVENT® 5100 DC (45/35)	G1.1/4"
6000	IBW-A DUOVENT® 6000 DC (80/60)	G1.1/4"
	IBW-B DUOVENT® 6000 DC (45/35)	G1.1/4"
7800	IBW-A DUOVENT® 7800 DC (80/60)	G1.1/4"
	IBW-B DUOVENT® 7800 DC (45/35)	G1.1/4"

For correct connection, the direction of water flow is indicated on the housing of the unit by auxiliary labels.

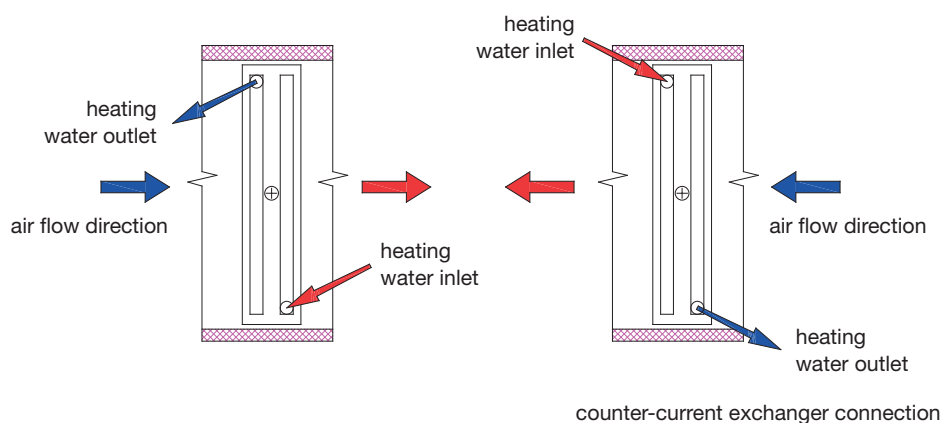



For the water heater to function properly, it is necessary to bleed the heater after connecting and filling the system with heating water. The vent screws are located directly at the heat exchanger connection necks. The vent screws are accessible either from the unit outer side or upon opening of the unit operation doors – see following figure.

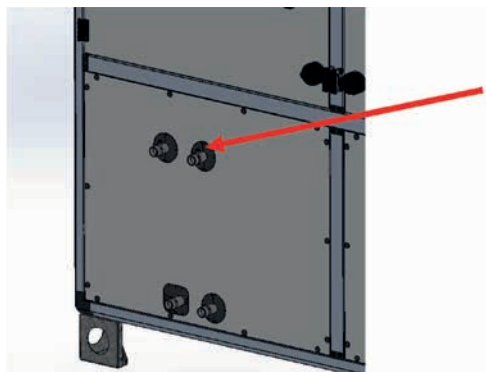

Before starting service work on the heat exchanger (when replacing it), it is necessary to drain the heating water distribution system connected to the heat exchanger and drain the heat exchanger itself using the drain screws on the heat exchanger collectors. The heat exchanger can then be disconnected from the heating water distribution system and removed from the unit.

Max. operating water temperature of water heaters: **+110 °C**

Max. operating water pressure of water heaters: **1,6 MPa**

Hydrogen exponent of heating water: pH 7-9

Heating water hardness: 1,0 mval / l

If necessary, water heaters can be operated with a heating medium based on a solution of water and ethylene glycol or propylene glycol - antifreeze mixture.

For water heaters, it is necessary to pay attention to the correct installation and function of the frost protection. The frost protection sensor is located on the heating water return, or a capillary frost protection thermostat is used (depending on the unit).

All pipes must be connected independently of the heat exchangers - the heating water pipes must not act on the necks of the heat exchangers due to their weight and expansion. We recommend the antifreeze mixture as a heat transfer medium for all outdoor units.

Units taken out of service must be protected against freezing by draining water from all parts of the unit. Residual water from the exchanger can be expelled with compressed air.

When starting the unit at an outdoor air temperature below +5 °C, the active fluid supply to the heater must be opened before starting the fan, which must have the projected temperature at the heating water supply to the heater. I.e. the boiler circuit must be in operation, the boiler must heat and provide the warm water to the system.



**CAUTION!**

For unit variants with water bivalence and heat pump (marked DXr DCA or DXr DCB in the unit code), it is recommended to use an antifreeze mixture of water and ethylene glycol (eg. FRITERM E Stabil) in min. concentration 1: 2 (i.e. 1 part of FRITERM E Stabil: 2 parts of water). If the antifreeze mixture cannot be used, a year-round supply of heating water must be provided in front of the water heater control valve so that all frost protection functions are active. For units that are not equipped with a Digireg control system, it is recommended to install a capillary antifreeze thermostat behind the water heater in the direction of air flow, which activates the antifreeze protection functions of the water heater in the customer control system of the unit.

## 5.2.5 WATER COOLER CONNECTION

A unit equipped with a water cooler (DCC unit code) is connected to the cooling medium by means of a three - way mixing unit (see „Types of ESUCH control units“). The water cooler outlets are located on the front or top part of the unit and are threaded. The exchanger must be connected in counter-current to the flow of air passing through (in concurrent connection, the exchanger loses approx. 25 % of its output). When tightening the heat exchanger connections, it is necessary, for example, to hold the heat exchanger neck with a second wrench so that the tightening torque is not transmitted to the heat exchanger body.

Table of dimensions of water cooler connection sockets:

Unit size	heater/cooler type	thread
500	IKW-DUOVENT® 500 DCC	G1/2"
1000	IKW-DUOVENT® 1000 DCC	G3/4"
1500	IKW-DUOVENT® 1500 DCC	G3/4"
2200	IKW-DUOVENT® 2200 DCC	G3/4"
3600	IKW-DUOVENT® 3600 DCC	G1.1/4"
5100	IKW-DUOVENT® 5100 DCC	G1.1/4"
6000	IKW-DUOVENT® 6000 DCC	G1.1/4"
7800	IKW-DUOVENT® 7800 DCC	G1.1/4"

For the correct connection of cooling water, the direction of water flow is indicated on the casing of the unit by auxiliary labels (the exchanger must be connected in counter-current):

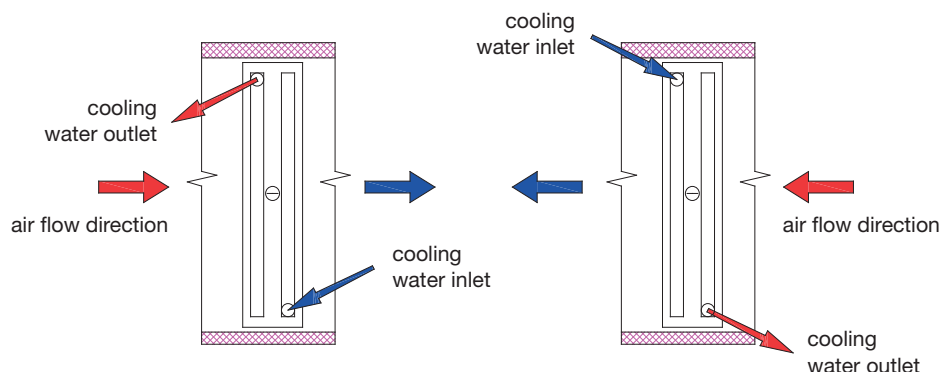

For the water cooler to function properly, the cooler must be vented after connecting and filling the system with cooling water. The vent screws are located directly at the heat exchanger connection necks. The vent screws are accessible either from the unit outer side or upon opening of the unit operation doors – see previous section.

Before starting service work on the heat exchanger (when replacing it), it is necessary to drain the heating water distribution system connected to the heat exchanger and drain the heat exchanger itself using the drain screws on the heat exchanger collectors. The heat exchanger can then be disconnected from the cooling water distribution system and removed from the unit.

Max. operating water pressure of water coolers: **1,6 MPa**

Hydrogen exponent of heating water: pH 7-9

Heating water hardness: 1,0 mval / l

The water cooler section is equipped with a drip eliminator, which must always be installed in the unit during cooler operation.

All piping must be installed independently of the heat exchangers - the cooling water piping must not act on the necks of the heat exchangers due to its weight and expansion. We recommend the antifreeze mixture as a heat transfer medium for all outdoor units.

Units taken out of service must be protected against freezing by draining water from all parts of the unit. Residual water from the exchanger can be expelled with compressed air.



DCA/DCB/DCC water exchanger can be used also for water with antifreeze mixture (based on propylene-glycol, ethylene-glycol etc.). We recommend e.g. concentrated antifreeze liquid FRITERM E STABIL or FRITERM P PLUS (recommended dilution for temperature resistance to -18°C 1 : 2 = 1 part FRITERM E STABIL: 2 parts of water). The recommended dilution for each type of coolant and the required frost resistance is included in the packaging of these antifreeze concentrates. For DCA / DCB / DCC water exchangers, we always recommend filling with antifreeze mixture with min. concentration of 20:80 because the liquids contain, among other things, inhibitors of corrosion. At least a minimum freezing resistance of the mixture (about -5 °C) is ensured.

### 5.2.6 DIRECT EVAPORATOR CONNECTION

The unit equipped with a direct evaporator (DX, DXr) is connected via a Cu pipe to the appropriate condensing unit or heat pump (the method and design of the connection is not the subject of these installation instructions). The direct cooler outlets are located inside or outside the unit (depending on the required design). The evaporator is filled with dry air or nitrogen from the factory. **After removing the valves on the evaporator necks, work on the refrigerant circuit assembly must begin immediately.** The connection of the refrigerant circuit for direct cooling must be carried out by a specialist company. It is mandatory to perform a „Refrigerant leak test“ on the refrigerant circuit. This test is performed only by a technician with the appropriate authorization (according to the law).

### 5.2.7 CONDENSATE DRAIN CONNECTION

To ensure the drainage of condensate the drain neck must be connected to the sewerage system via a siphon with an odour trap. The siphon must be located next to the unit. The condensate drain is as standard located on the exhaust part of the degraded air and below the cooler or evaporator.

Location of condensate drain necks:

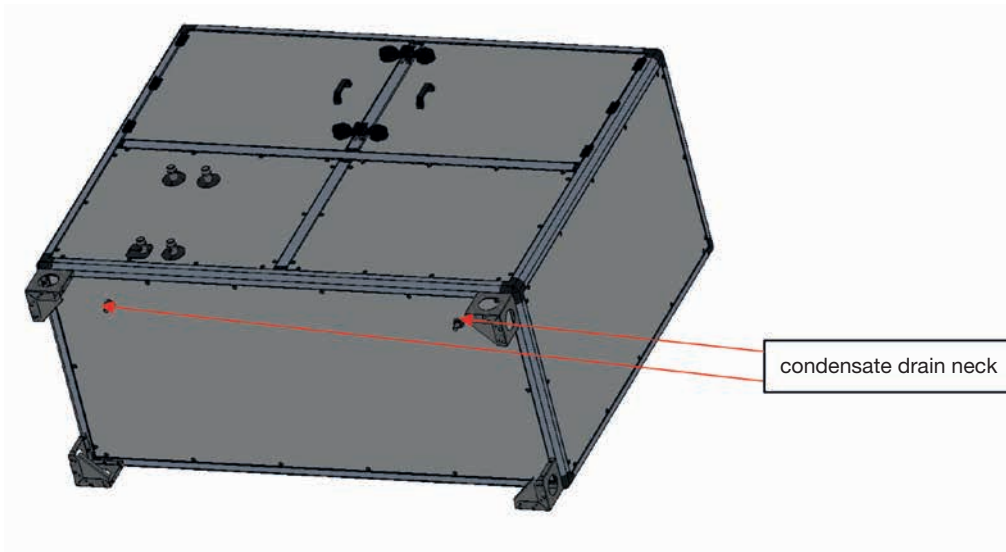

Vacuum type siphon scheme (SF-P 300):

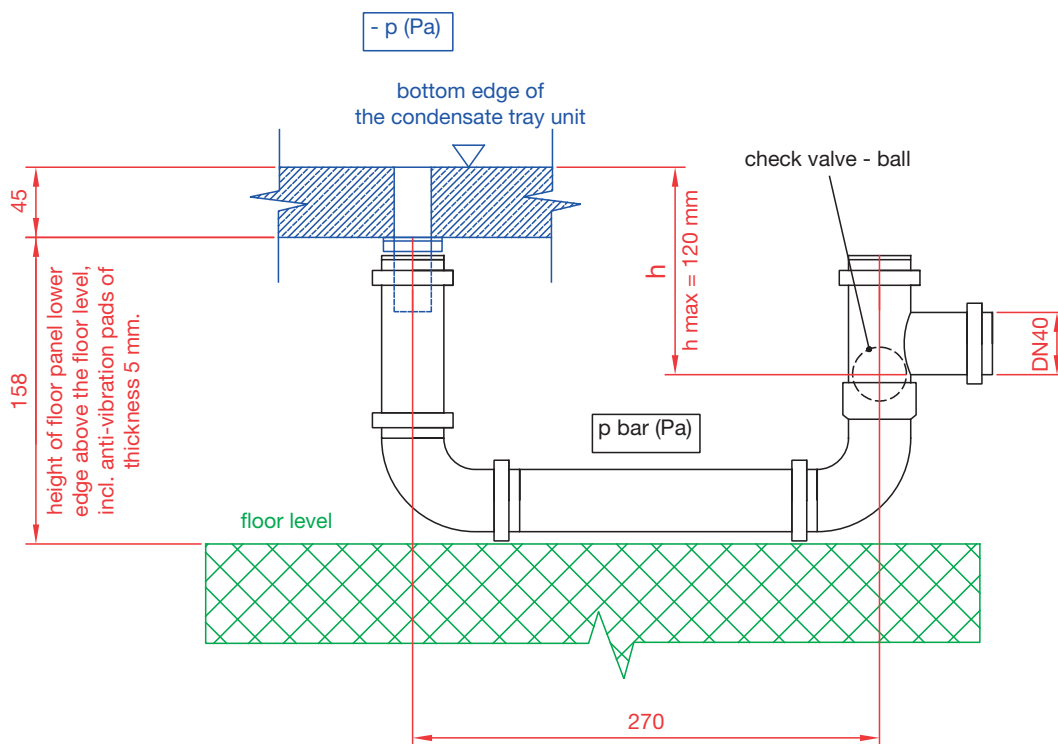

The vacuum siphon (SF-P300) contains a ball that serves as a non-return valve for the proper function of the water-free siphon and prevents odours from entering the unit. The siphon must be fitted to the unit gas-tightly via the enclosed rubber sleeve. Maximum usable vacuum 1100 Pa.

Siphon working height:

$$h = 10 + (\Delta p / 10) \dots (\text{mm})$$

$\Delta p$  ... absolute value of vacuum or overpressure at a given location of the unit



INSUFFICIENT SIPHON WORKING HEIGHT CAUSES COLLECTION OF THE CONDENSATE IN CONDENSATE TRAY OF THE UNIT. THEN THE CONDENSATE RUNS OUT OF THE UNIT!!!

For DUOVENT® COMPACT DV TOP units, one condensate drain neck is located in the vacuum part of the unit and one neck is located in the overpressure part of the unit! I.e. the absolute pressure in the unit is lower than the barometric pressure in the outer vicinity of the unit - applies to the vacuum neck! When the siphon is not connected air is sucked in from around the unit at a very high speed through the condensate drain (hole  $\varnothing$  16 mm) -> the air sucked into the unit will prevent the condensate from draining out of the condensate tray!!!

### 5.2.8 BYPASS AND MIXING FLAP

In the basic version, each unit is equipped with a bypass flap of the plate heat exchanger (BP). The bypass is used for summer ventilation, defrost control of the recuperation exchanger in the event of a threat of icing and to regulate the efficiency of the recuperation exchanger. In conjunction with a mixing flap or circulation flap (marked MX or C in the unit code), fresh air is mixed with the required amount of exhaust air in the bypass area. If the unit is MX or C, it also has an integrated mixing flap, which is located opposite the bypass flap. This damper allows you to efficiently mix part of the exhaust air with fresh air, or allows the unit to have a circulation mode where only the supply fan is running. This mode is mainly used for preheating or pre-cooling to the desired temperature.

Location of mixing and bypass damper for DUOVENT® 500, 1000 TOP units:

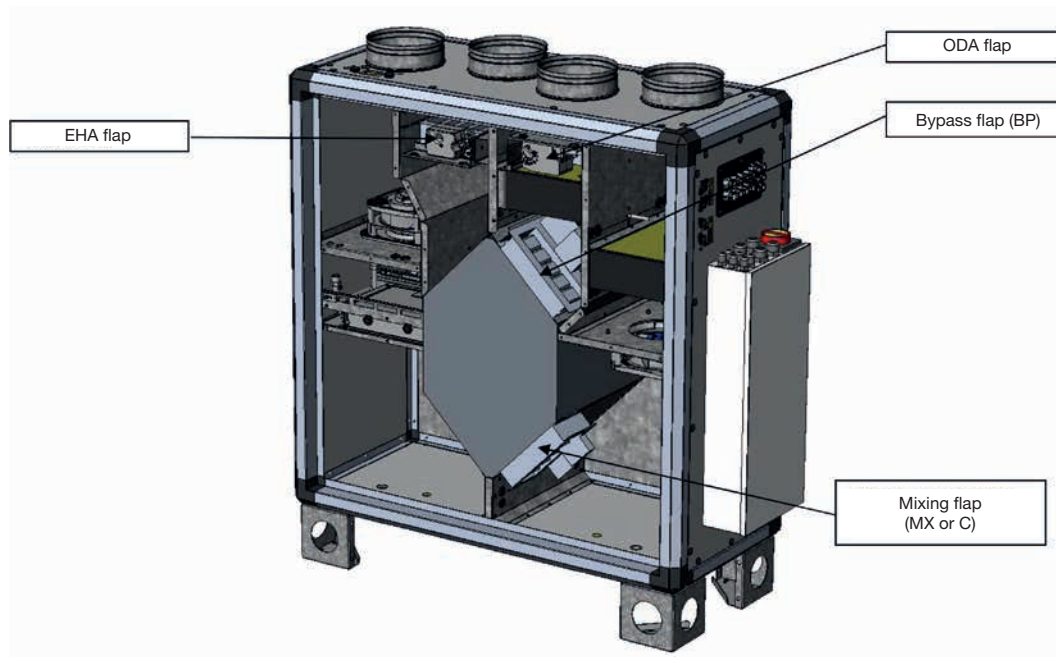

Location of mixing and bypass flap for DUOVENT® 1500.2200, 3600 TOP units:

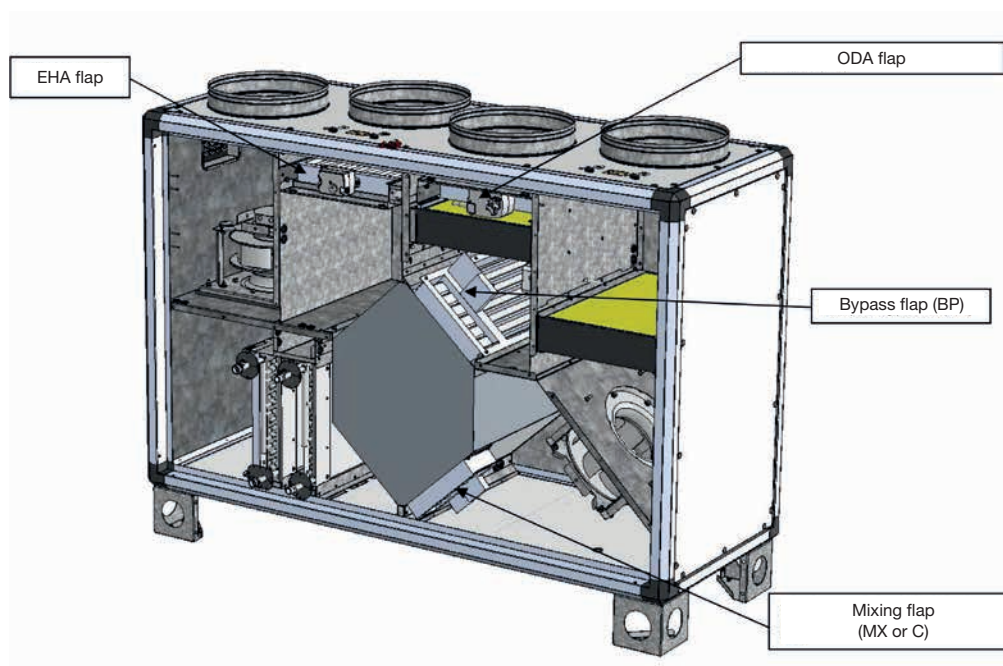

Location of mixing and bypass flap for DUOVENT® 5100.6000, 7800 TOP units:

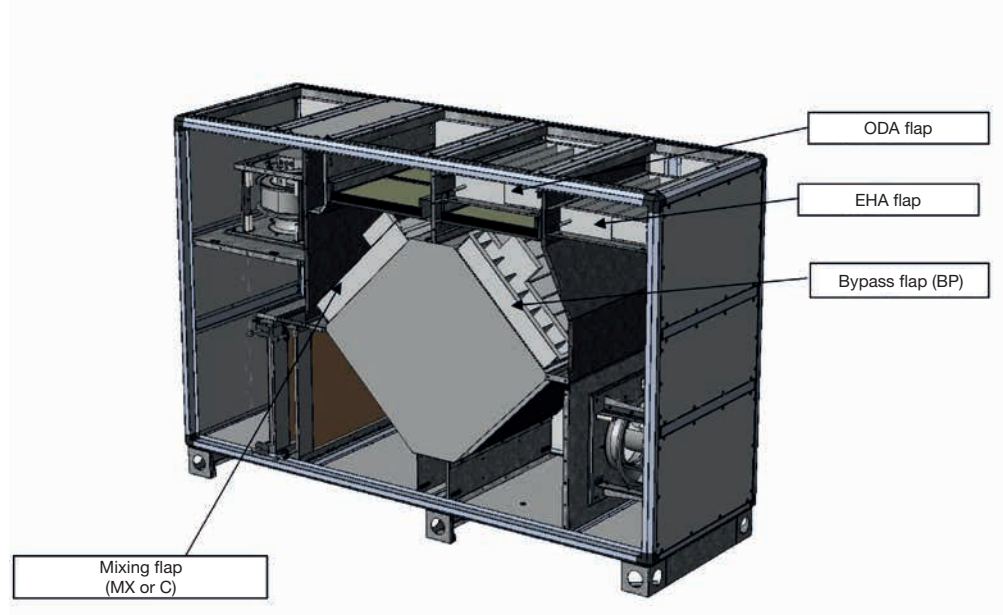

Control torques and types of bypass and mixing flap actuators:

unit type	min. control torque [Nm]	possible types of BELIMO actuators
DUOVENT® 500 to 1500 TOP	2	CM24-SR-L or R / CM24-L or R / CM230-L or R
DUOVENT® 2200 to 7800 TOP	5	LM24A / LM24A-SR

The exchanger bypass flap can be controlled by an ON / OFF actuator (LMxxA, CMxx) or a continuous actuator (LMxxA - SR, CMxx-SR). It is recommended to control the mixing flap only with a continuous type of actuator (xxxx-SR).

The location of the actuator is on the back of the flap - after opening the front door opposite to the view side. **For better accessibility, it is recommended to install the actuator before starting to connect the unit to the piping network.**

### 5.2.9 INLET AND EXHAUST FLAP (ODA-FRESH AIR, ETA-EXHAUST AIR)

The basic version of the unit is equipped with a fresh and exhaust air inlet flap (ODA and ETA). The arrangement of the flaps in the unit is shown on the picture above.

When using a variant of the unit with a water heater DCA or DCB, it is recommended to mount an actuator with an emergency function on the fresh air inlet flap.

Control torques and types of inlet damper actuators:

unit type	min. control torque [Nm]	possible types of BELIMO actuators	possible types of BELIMO actuators with emergency function
DUOVENT® 500 to 1500 TOP	2	CM24-L or R / CM230-L or R	TF24 / TF230
DUOVENT® 2200 to 7800 TOP	5	LM24A	LF24

## 5.2.10 BASIC ACCESSORIES

### 5.2.10.1 CONDENSATE DRAIN TRAPS

Condensate traps must be ordered as a separate item as they are not included with the unit.

Vacuum type siphon scheme (SF-P 300):

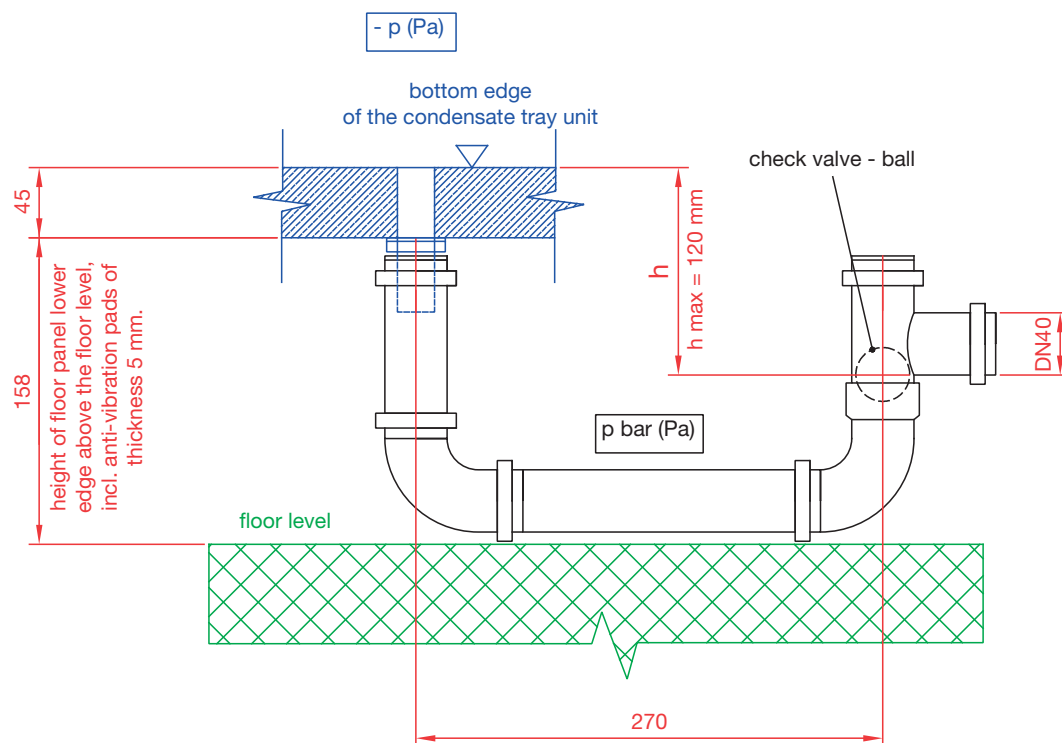

The vacuum siphon (SF-P300) contains a ball that serves as a non-return valve for the proper function of the water-free siphon and prevents odours from entering the unit. The siphon must be fitted to the unit gas-tightly via the enclosed rubber sleeve. Maximum usable vacuum 1100 Pa.

### 5.2.10.2 ESU WATER HEATER OR ESUCH WATER COOLER CONTROL UNIT

The ESU or ESUCH unit must be ordered as a separate item because they are not included with the unit.



The mixing control unit is used to control the flow or temperature of heating (cooling) water to the water heaters/coolers. The ESU unit regulates the heating water temperature at the inlet to the water heater by mixing the inlet water and return line, the ESUCH unit regulates the flow of cooling water to the water cooler at a constant cooling water inlet temperature. (The designation xx in the type symbol indicates the type of GRUNDFOS pump, indicates the Kv value of the mixing valve). The control is provided by a BELIMO servomotor. For control units in conjunction with Digireg® control, it is necessary to use the design B, which features a three-point actuator, designed for control by a Digireg® controller. Version A can be controlled by a 0... 10 V signal. In addition to power regulation, the control system also provides protection of the water heater against freezing by means of the ESU unit. The water flowing through the unit may not contain impurities, solid admixtures and aggressive chemicals that damage copper, brass, stainless steel, zinc, plastics, rubber. The highest permitted operating parameters of the heating water are as follows:

- maximum water temperature +110°C
- maximum water pressure 1 MPa
- minimum water pressure 20 kPa

The water temperature must not fall below the ambient air temperature during operation, as there is a risk of condensation in the pump motor. The minimum operating water pressure ensures that no air is sucked in by the vent valve, which must be mounted at the highest point of the water circuit. For the ESUCH unit, it is always necessary to install insulation against condensation of air humidity on the surface of the node on the entire node (suitable material is e.g. Armaflex).

Layout diagram of node components:

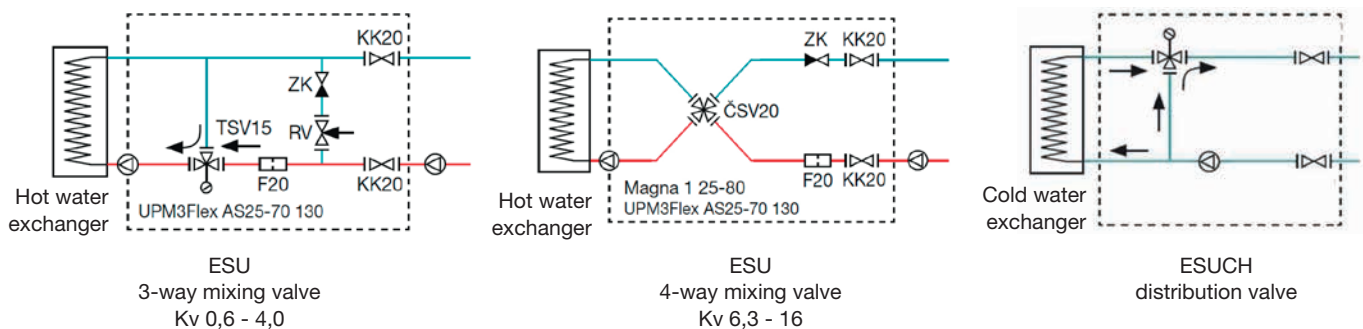

**CAUTION!**  
The design of a suitable mixing unit must be individually adapted to the conditions of the application in order to ensure sufficient valve authority!

The mixing unit is connected to the heater or cooler. The mixing unit must never be loaded by tension and twisting of the connected piping. Mixing units should be mounted on separate hinges using heating sleeves on the wall, pipes or on an auxiliary structure. When placed under the ceiling, it is necessary to maintain control and service access to the mixing unit for easy cable connection and service access. The filter requires regular inspection, maintenance and cleaning. **When assembling the node, it is necessary to turn the filter downwards with the sludge pan. If the position is incorrect, there is a risk of increased clogging/choking of the filter. Reduced throughput or even impermeability of the filter results in a significant reduction in heater performance and increases the risk of the heater freezing. Especially during the test operation, it is necessary to check and clean the sludge pan.**

If the filter is often clogged, the entire heating circuit must be cleaned. Even during normal operation of the device, it is necessary to check the filter regularly. When cleaning the filter, all water lines must be closed to minimize water leakage from the system. Always install the mixing unit so that air can escape to the heater vent points or the boiler circuit vent points. The mixing unit must be fixed so that the pump motor shaft is in a horizontal position. After flooding the system, the circulation pump must be bled according to the manufacturer's instructions (Grundfos). When connecting the mixing unit, it is necessary to check the correct setting of the valve and actuator. With an assembled mixing unit, the position of the inner segment of the mixer can be identified by the shoulder on the front of the shaft extension. The perpendicular line to the mounting surface at the three-way valve points to the axis of the inner segment. For the version with a three-way valve, proceed as follows. Of the three paths, the valve always has the path to which the bevelled surface on the valve shaft points. With an assembled mixing unit, the setting can be identified by the notch on the face of the shaft extension. The notch always points to a closed water line - see following image.

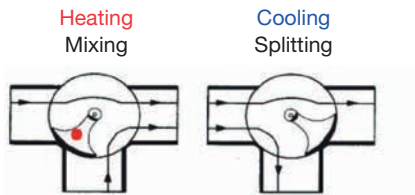

## 6. ELECTRICAL INSTALLATION

In general, it is necessary to observe the provisions of ČSN 12 2002 and other related regulations. The device must be disconnected from the mains during any inspection or service activities. The connection and earthing of electrical equipment must comply in particular with ČSN 33 2000-5-51 ed.3, ČSN 33 2000-5-54 ed.3 and the ČÚBP and ČBÚ decrees on professional competence in electrical engineering no. 50.

The connection of the DUOVENT® unit equipped with the Digireg® I&Ccontrol system to the electrical distribution network is made by a separate supply cable, which is not part of the delivery of the device.

### 6.1. CONNECTION OF FAN ELECTRIC MOTORS

Fan connection terminal block for sizes DV 500 TOP:

TERMINAL BLOCK 1.1

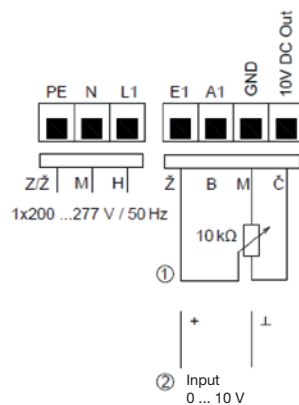

Z/Ž - green-yellow – PE conductor  
M - Blue – N conductor  
H - Brown – L1 conductor

Ž - Yellow – E1 signal  
B - White – A1 signal  
M - Blue – zero potential GND  
Č - Red – power source 10 V DC

Fan connection terminals for sizes DV 1000, 1500 TOP:

TERMINAL BLOCK 1.2

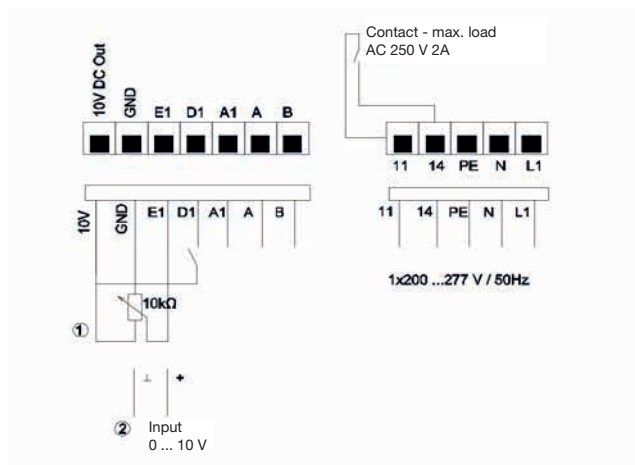

Fan connection terminals for sizes DV 2200–7800 TOP:

TERMINAL BLOCK 1.3

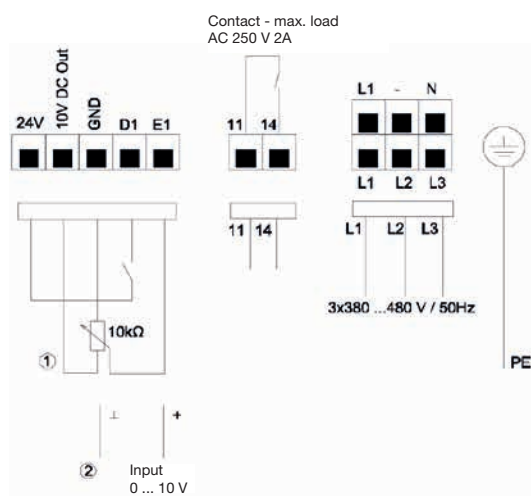



**Legend for connection of terminal blocks:**

①- Entered speed, e.g. of external potentiometer REB-Ecowatt. Connected to terminals „+10 V“ and „GND“ with sensor at terminal „E1“.

②- Excitation via external signal 0... 10 V.

**L1, N, PE** – network connection for types 1~

**L1, L2, L3, PE** – mains connection for types 3~

**11,14** – relay output for fault reporting. During operation, terminals „11“ and „14“ are bridged (relay is closed). In the event of a fault, the relay opens. When switched off with D1 (digital input set to 1), the relay remains closed.

**E1, GND** – analog input for entering the speed 0... 10 V

**10 V DC Out** – voltage supply for entering the speed using an external potentiometer REB-Ecowatt

**D1,+24 V (resp.+10 V)** – digital input. Fan on = contact closed. Fan off = contact open

**A1** – status/tacho open-collector output (Imax = 20 mA)

**A,B** – Modbus (RS-485) interface

Fan connection terminal block for sizes DV 1000, 1500 TOP (with fan type K3G):

TERMINAL BLOCK 1.4

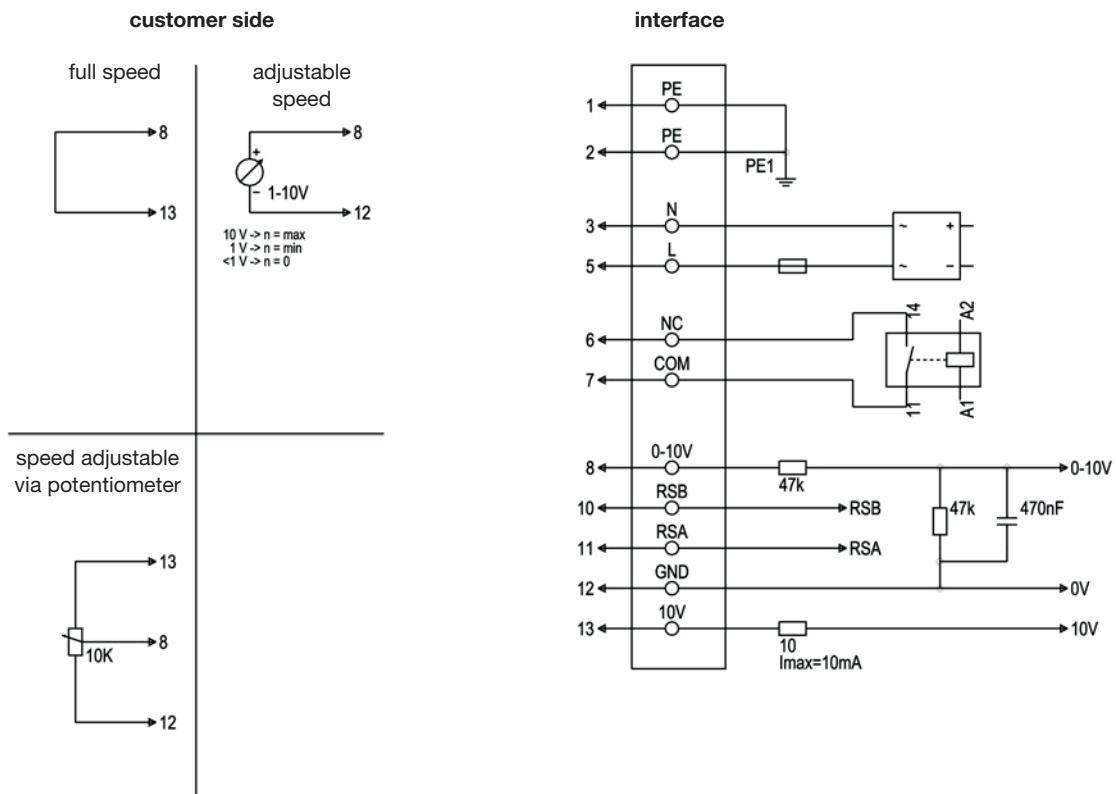

No.	fol.	marking	colour	function/assignment
1	1, 2	PE	green / yellow	protective conductor
1	3	N	blue	supply voltage, neutral conductor, 50/60 Hz
1	5	L	black	supply voltage, phase, 50/60 Hz
1	6	NC	white 1	status relay, potential-free contact of status message; contact opened with fault, contact rating 250 V AC/2 A (AC1) min. min. 10 mA, basic insulation against the mains and reinforced insulation against the control interface
1	7	COM	white 2	status relay, potential-free contact of status message, common connection, contact rating 250 V AC / 2 A (AC1) / min. min. 10 mA, basic insulation against the mains and reinforced insulation against the control interface
2	8	0 - 10 V	yellow	analogue input (setpoint) 0-10 V, Ri = 100 kΩ; parametrizable characteristic
2	10	RSB	brown	RS485 interface for MODBUS, RSB
2	11	RSA	white	RS485 interface for MODBUS, RSA
2	12	GND	blue	reference ground for control interface, SELV
2	13	+10 V	red	fixed voltage output 10 V DC; +10 V ±3 %, max. 10 mA; permanently resistant to shortage, power voltage for ext. equipment (e.g. potentiometer)

Fan connection terminal block for sizes DV 2200, 3600 TOP (with fan type R3G):

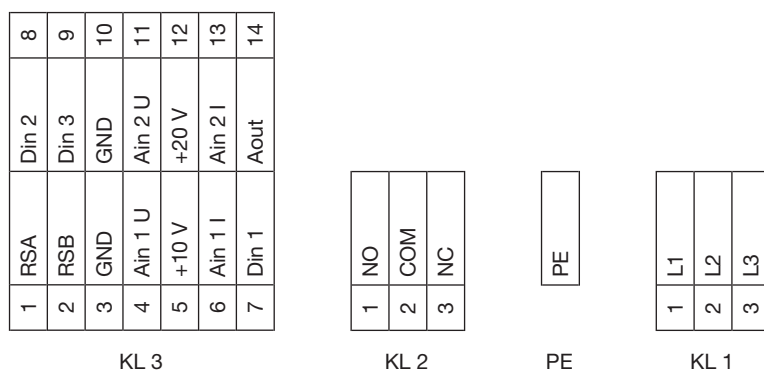

### Legend:

**PE** – protective conductor

**L1, L2, L3** – supply voltage, phase, 3x400 V 50 Hz

**NC** – status relay, potential-free status message, contact opened in case of error

**COM** – status relay, potential-free status reporting contact, common connection, contact rating 250 V AC / 2 A (AC1) min. 10 mA

**NO** – status relay, potential-free status message, contact closed in case of error

**RSB** – RS485 interface for Modbus, RSB

**RSA** – RS485 interface for Modbus, RSA

**GND** – reference frame for control interface, SELV

**Ain 1 U** – analogue input 1 (setpoint) 0-10 V, Ri = 100 kΩ, parametrizable characteristic, only usable as an alternative to input Ain 1 I

**+10 V** – fixed voltage output 10 V DC, +10 V ±3 %, max. 10 mA; permanently resistant to shortage, power voltage for ext. equipment (e.g. potentiometer)

**Ain 1 I** – analogue input 1 (setpoint) 4-20 mA, Ri = 100 Ω, parametrizable characteristic, only usable as an alternative to input Ain 1 U

**Din 1** – digital input 1: electronics activation  
 activated: pin open or voltage supplied 5-50 V DC  
 deactivated: jumper with GND or voltage < 1 V DC applied

**Din 2** – digital input 2, switches parameter setting „1“ or „2“, in accordance with EEPROM setting, valid or used parameter can be selected via Modbus or digital input DIN2  
 parameter 1: pin open or voltage supplied 5-50 V DC  
 parameter 2: jumper with GND or voltage < 1 V DC applied

**Din 3** – in accordance with the EEPROM setting, the setting of the control direction can be set to normal or inverse, the used parameter can be selected via the Modbus bus or digital input DIN3  
 normal: pin open or voltage supplied 5-50 V DC  
 inverse: jumper with GND or voltage < 1 V DC applied

**Ain 2 U** – analogue input 2 (setpoint) 0-10 V,  $R_i = 100 \text{ k}\Omega$ , parametrizable characteristic, only usable as an alternative to input Ain 2 I

**+20 V** – fixed voltage output 20 V DC, +20 V +25/-10 %, max. 50 mA; permanently resistant to shortage, power voltage for ext. equipment (e.g. sensor)

**Ain 2 I** – analogue input 2 (setpoint) 4-20 mA,  $R_i = 100 \Omega$ , parametrizable characteristic, only usable as an alternative to input Ain 2 U

**Aout** – analogue output 0-10 V DC, max. 5 mA, output signals actual motor control level

## 6.2 ELECTRIC HEATER CONNECTION

The cables of the electric heater are led to the terminal board of the electric heater and properly marked for the subsequent connection of the control and management system.

Type connection of the electric heater terminal block for DUOVENT® units:

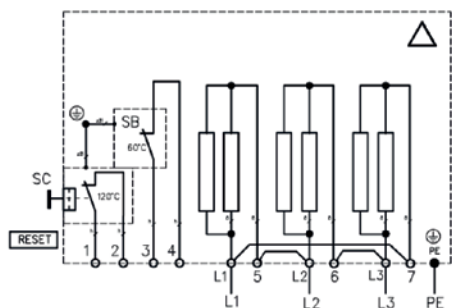

SC ... emergency thermostat with manual reset  
 SB ... operating thermostat with automatic reset



**CAUTION!**  
 SB and SC safety devices must always be connected to the contactor circuit of the electric heater!

## 6.3 INSTRUMENTATION AND CONTROL (I&C) SYSTEM

The standard part of the unit is its own control system. The design of the unit is ready for cooperation with the Digireg® digital controller.

### 6.3.1 DIGITAL REGULATION SYSTEM DIGIREG®

The control system is located in a compact sheet steel switchboard equipped with a main switch, digital controller on the PCB board and safety and switching elements for individual HVAC units. The cables pass through plastic bushings with locking in the left side of the cabinet.

Basic dimensions of Digireg® M3-Vx switchboard with protection level IP20:

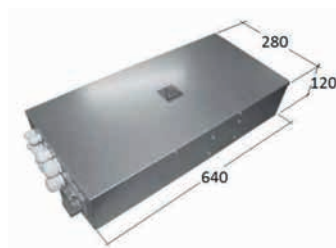

The switchboards M1-E2 to M3-E36 have dimensions 660 x 660 x 120 mm.  
 The Digireg® switchboard with IP65 protection has dimensions of 640 x 600 x 210 mm.

### 6.3.2 TEMPERATURE REGULATION

The Digireg® controller is designed to control the output of the heater or cooler of the air handling unit to reach the desired temperature.

The Digireg® can command direct cooling or a heat pump. There is a 3-point output for servo drive of the mixing valve, direct power outputs SSR for electric heating or two analogue outputs 0–10 V / 0–20 mA. The heat pump or cooling unit is controlled by potential-free contacts.

- **Regulation to a constant supply air temperature**  
uses one temperature sensor in the supply pipe, the supply air is heated or cooled to the required set temperature within the minimum and maximum configured temperature
- **Regulation to a constant temperature of the exhaust air**  
uses one temperature sensor in the exhaust pipe, the supplied air is heated or cooled to the required set temperature within the minimum and maximum configured temperature
- **Spatial temperature control (for constant room temperature)**  
Cascade control is used with limitation of the minimum and maximum supply air temperature. The main sensor is placed in a ventilated area, the supply air sensor is placed in the outlet of the unit in a place with sufficient air mixing. If the room temperature is higher than the set value, the controller will try to reduce the supply air temperature to the set minimum supply air temperature. If the room temperature falls below the set value, the controller tries to compensate for this by increasing the supply air temperature. The room temperature can be selected as the room temperature, the temperature from the sensor in the controller, or from a separate sensor connected to the motherboard. The controller cools or heats according to the set parameters in the automatic summer/winter mode according to the outdoor temperature and time dependencies. Manual mode selection is also possible. The heater can be hot water, controlled by a three-point actuator, or electric, directly controlled by SSR, or external TRIAC switches 0-10 V. Electric heater controlled by internal SSR can have up to 36 kW depending on the cabinet, water heater is not limited mixing unit size). Cooling can be cold water, controlled by a 0-10 V analog actuator or direct in conjunction with a condensing cooling unit.



**CAUTION!**  
For units with a direct evaporator (marked DX and DXr in the unit code), it is possible to maintain the required air temperature in the room with accuracy, depending on the correctness of the project and the correct function and setting of the ventilation system with accuracy of  $\pm 2^{\circ}\text{C}$ .

### 6.3.3 INSTALLATION

Controllers with IP20 protection are designed for installation in an indoor dry environment without aggressive chemicals in normal areas according to ČSN 33 2000-3, ambient temperature up to 30 °C.

The short-circuit resistance of the Digireg® switchboard is 6 kA. Distribution board protection is IP20 or IP65 and the material is listed below in the catalog sheets at [www.elektrodesign.cz](http://www.elektrodesign.cz).



**CAUTION!**  
Digireg® distribution boards are not designed for direct installation to the flammable material!



For heat recovery units supplied with a free located Digireg® control box, which is not fixed to the unit wall, the firm housing must be ensured of harness between the unit and control box in the firm cable line (such as cable trays, cable bench etc.). The harness between the unit and the control box shall not be freely suspended or positioned on the floor!!! After firm laying of the harness it is possible to start the works on connection of individual wires to the Digireg® control box.

Cross-sections of power cables (fans, pumps, electric heaters...) must be designed according to specific installation conditions in accordance with ČSN 33 2000-5-52 ed.2.

The installation must be carried out by an authorized person working on electrical equipment in accordance with legal requirements and familiar with the function of the individual components of air conditioning and control. Observe the valid ČSN during installation. **An initial inspection must be performed before commissioning.**

For the assembly and installation of air conditioning, an authorized project of air conditioning and M&R is required, which solves both the air outputs and the piping system, as well as the electrical connection of elements and operating modes.

The actual commissioning and setting of the basic parameters of the controller must be performed by an authorized company with authorization and training from ELEKTRODESIGN ventilátory, s.r.o.

The cables must be secured outside the unit against being pulled out in the installed bushings. The cable routes of safe and mains voltage must be separated due to electromagnetic compatibility requirements. It is necessary to build 2 cable routes at a distance of at least 20–30 cm from each other, if possible with a minimum of crossing. A grounded metal partition in the entire height of the metal grounded gutter is also permissible

If the main supply has a conductor cross-section of less than 6 mm<sup>2</sup>, we recommend connecting the controller to the earthing system with a copper conductor with a cross-section of at least 6 mm<sup>2</sup> due to the impedance of the earth conductor for high-frequency interference. We recommend to fit the power supply with surge protectors.

It is necessary to check the function of all connected elements, especially emergency inputs, the direction of rotation of the fans, the correct phasing of the damper actuators and mixing valves. If the unit is equipped with Digireg® control system directly from the factory, a SETPACK test package has been performed on the unit. SETPACK covers basic settings of control system parameters and testing of all peripherals.

**6.3.4 TECHNOLOGY SCHEME OF DIGIREG® I&C SYSTEMS**

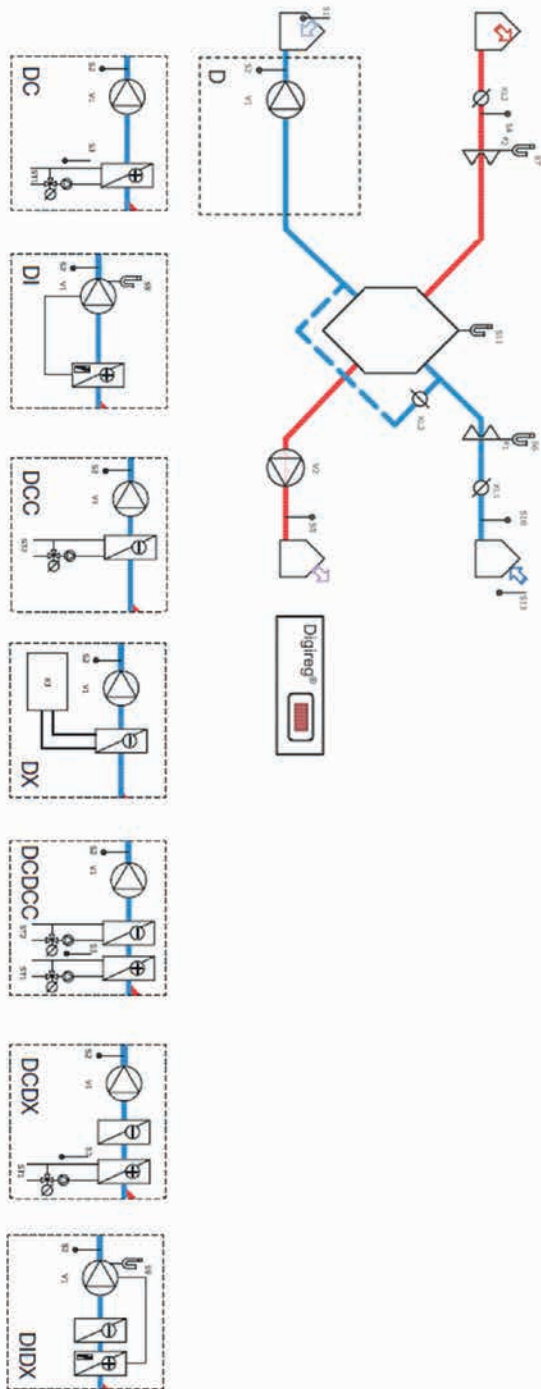

**Legend to schemes**

- S1 room temperature sensor
- S2 supply air temperature sensor
- S3 temperature sensor for frost protection of water heating
- S4 temperature sensor for exhaust air
- S5 exhaust air temperature sensor
- S6 pressure sensor on the supply filter
- S7 drain filter pressure sensor (optional)
- S8 thermostat as protection against freezing of the direct evaporator
- S9 supply fan pressure sensor (mandatory - monitors fan operation)
- S10 intake air temperature sensor
- S11 recuperator icing sensor
- S13 outdoor temperature sensor (enable condenser unit operation)
- V1 supply fan
- V2 exhaust fan
- KL1 inlet flap actuator (circulation)
- KL2 outlet flap actuator (can be coupled with KL1)
- KL3 recuperator bypass actuator
- KL4 mixing actuator for integrated flaps
- ST1 heating water mixing valve actuator
- ST2 cooling water mixing valve actuator
- KJ condensing unit

**6.3.5 CONTROL**

The controller is operated exclusively via the touch control. Service settings are performed by the appropriate service program, which is only available to trained and certified companies.

Touch control CP for Digireg®



Detailed settings and control of the controller are in the manuals for individual control systems. The instructions are available at [www.elektrodesign.cz](http://www.elektrodesign.cz).

## 7. COMMISSIONING

The device may only be put into operation for the first time by a suitably qualified specialist.

### 7.1 INSTALLATION AND CONNECTION CHECK

Before the first commissioning, it is necessary to check:

- Equipment cleanness, installation completeness/quality
- Fan free rotation
- Operating voltage of installed control system
- Operating voltage of electric motor acc. to type plate
- Actuator control and operating voltage
- Function of condensate drain and trap water flooding
- Cleanness of filter cartridges
- Flap movability
- Tight connection to distribution lines
- Closing of all doors and service holes

Any faults must be rectified before starting the unit for the first time.

### 7.2 TRIAL OPERATION

The material content of the comprehensive testing includes the commissioning of the device for a pre-agreed time and its continuous inspection. In order to comply with the required air parameters depending on the operation of the building and the technology, it is necessary to fine-tune the device during the test operation, or during the warranty tests.

For the first start of the air handling unit, the company ELEKTRODESIGN ventilátory, s.r.o. offers the **STARTPACK** assistance service package. Find out about the conditions and scope of the **STARTPACK** package at [www.elektrodesign.cz](http://www.elektrodesign.cz).

The company putting the unit into operation is obliged to demonstrably train the user's staff. Without proof of operator training, the warranty will not take effect and the device must not be operated.

## 8. OPERATION AND MAINTENANCE

These instructions serve as an aid for professionals, operators of air handling units, or investors who are assumed to already have experience with the operation of air conditioning systems. The instructions are especially important for the start-up period of the entire system, when more detailed operating regulations are not available. The purpose of these instructions is to allow temporary operation of air handling units and to prevent possible operator errors. Final operating regulations must be prepared in accordance with the operating regulations of the entire building.

### 8.1 SAFETY INSTRUCTIONS FOR OPERATION AND MAINTENANCE

Follow all safety recommendations to prevent damage to the fans or personal injury. The technical characteristics of this manual must not be changed. The motors of the unit must not be changed. The unit can be connected to a three-phase AC mains supply 400 V / 50 Hz or single-phase 230 V / 50 Hz networks for sizes DV 500 and DV 1000. For installation in accordance with EC regulations, the units must be connected to the mains only in accordance with the applicable regulations. The device must be installed in such a way that, under normal operating conditions, it cannot come into contact with any moving or live part. DUOVENT® Compact DV TOP units comply with the applicable regulations for electrical equipment. Always disconnect the device from the power supply before carrying out any work on the device. Always use the appropriate tools. Use the device only for its intended purpose.

### 8.2 EQUIPMENT SERVICE

To maintain the efficiency of DUOVENT® COMPACT DV 500 to 7800 TOP units, regular maintenance is required.



**CAUTION!**

- The unit must be disconnected from the power supply. The unit service switch is locked in OFF position.
- The fan impellers shall not rotate!
- Electric heater bars must be cooled to min. 30°C!

## 8.2.1 FILTER REPLACEMENT AND MAINTENANCE

The filter replacement interval can vary considerably depending on the operating conditions and where the unit is located (the level of outdoor pollution depends on the location near industrial areas, roads or highways, forests or agricultural areas). The filter change interval ranges generally from 6 to 12 months. After unlocking the locks, open the relevant door of the unit. Pull together to remove and then replace all filters on the unit.

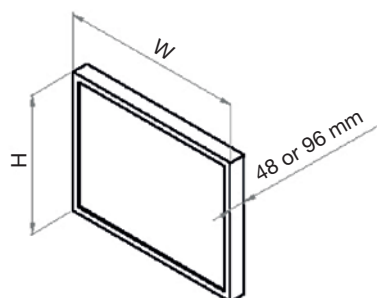
Plate filter dimensions:



For size DV 500-3600 - filters ONLY 96 mm thick:

Size DUOVENT® DV TOP	Vnom [m³/h]	Bf [mm]	Af [mm]
500	500	214	420
1000	1000	252	577
1500	1500	370	577
2200	2200	410	734
3600	3600	445	891

For size DV 5100-7800 - 48 mm or 96 mm thick filters:

Size DUOVENT® DV TOP	Vnom [m³/h]	Bf [mm]	Af [mm]	Filter cartridge size for DV 5100-7800 filter walls						total number of filters
				Š [mm]	V [mm]	Š [mm]	V [mm]	Š [mm]	V [mm]	
5100	5100	550	891	550	420	550	471	-	-	2
6000	5900	550	1048	550	471	550	577	-	-	2
7800	7400	550	1362	550	471	550	420	550	471	3

Filter replacement procedure - after opening the operator's door, the filters can be removed by sliding them off the rails (applies to DUOVENT® DV 500 - 7800 TOP unit sizes)



## 8.2.2 FAN MAINTENANCE

The fans are protected by filters and can therefore only be slightly soiled. Nevertheless, it is recommended to perform a visual inspection every 5 years. Remove dust from the impeller with a dry (not wire!) brush or by blowing with compressed air. Check the condition of the electric motor bearings. If you need to replace the entire unit or fan, open the door by opening the locks by turning 90°. The fan is located on rubber silent blocks. Loosen the 4 nuts, lift and remove the fan as shown in the following figure. Keep in mind that the fan must be dynamically and statically balanced again after removing the electric motor.

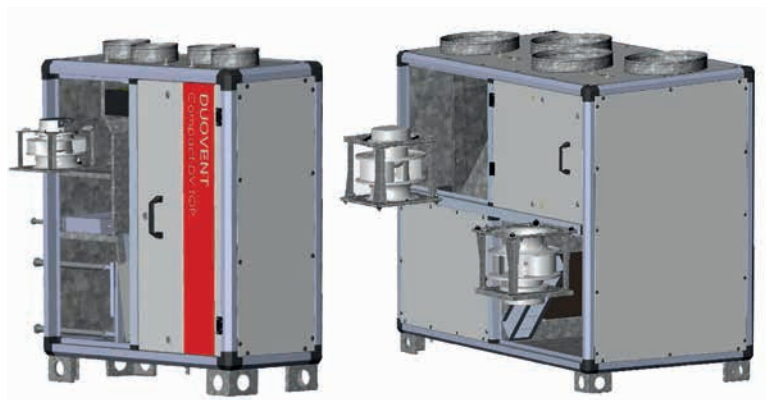

### 8.2.3 RECUPERATION EXCHANGER MAINTENANCE

The heat recuperation exchanger is protected by filters and can therefore only be contaminated very lightly. Nevertheless, it is recommended to perform a visual inspection every 5 years. If necessary, open the front door by opening the locks by turning it. Remove dust from the boards with a dry brush (not wire!) Or by blowing with compressed air.

### 8.2.4 PERIODIC INSPECTIONS

Perform periodic inspections at least once a year as part of a summer service inspection. It is optimal to carry out inspections twice a year, usually before and after the end of the winter season.

During the regular service inspection it is necessary in particular:

- Perform regular inspection and cleaning of the heat exchange surfaces of the exchangers
- Clean or replace filter inserts in air filters
- Check the condition of the damping inserts, especially their tightness, and replace them in time
- Perform inspections and checks of the function of electrical components (contactors contacts, tightening of terminals, condition of insulation...)
- Check the hinges and supports of the device
- Carry out regular inspections of those facilities for which the applicable laws, decrees, standards and rules so require
- Keep proper records and monitoring of the outcome of inspections and revisions and monitor the implementation of the measures taken
- Check the siphons for condensate drainage, especially their permeability and tightness, especially the tightness of the mounting on the unit and the tightness of the ball seating

### 8.2.5 SPARE PARTS

Warranty, post-warranty service and spare parts can be ordered from ELEKTRODESIGN ventilátory spol. s r.o. The manufacturer may entrust service to trained authorized service companies. Their list is at [www.elektrodesign.cz](http://www.elektrodesign.cz). **Contact details for authorized service are indicated on the yellow labels on each unit.**



#### AUTHORISED SERVICE CENTER

ELEKTRODESIGN ventilátory s.r.o.

Tel.: +420 326 909 038

E-mail: [servis@elektrodesign.cz](mailto:servis@elektrodesign.cz)

- repairs and service of ELEKTRODESIGN HVAC units
  - repairs and service of HVAC units from other manufacturers
  - sale of spare parts, replacing of filters
- MO-FR 8:00-16:00



#### WARNING

Do not start and/or use the unit during constructions works (drilling, grinding etc.). There is a risk of unrepairable damage of the unit and distribution lines! The unit must be commissioned by an authorized person only!

If these instructions are violated, the manufacturer has no responsibility for any subsequent losses and the warranty for the HVAC unit becomes void!

## 9. DECOMMISSIONING AND RECYCLING



EU law and our responsibility to future generations oblige us to recycle used materials; do not forget to dispose of all unwanted packaging materials at the appropriate recycling points and dispose of obsolete equipment at the nearest waste disposal site.

In case of any questions regarding our products, please contact any branch of ELEKTRODESIGN ventilátory spol. s r.o. To find your nearest dealer, visit our website [www.elektrodesign.cz](http://www.elektrodesign.cz).



## Annex number 1

### INFORMATION ON COMMISSION REGULATION (EU) NO 1253/2014 (ANNEX 5, POINT 3)



#### INFORMATION REQUIREMENTS FOR VENTILATION UNITS FOR NON-RESIDENTIAL BUILDINGS UNDER ART. 4 PARAGRAPH 2.

DUOVENT® Compact series units contain parts with a proportion of plastic and electronic components intended for disassembly and subsequent recycling:

1. FLAP ACTUATORS
2. DTS PSA PRESSURE SENSOR
3. FAN IMPELLERS
4. PLASTIC PARTS OF FAN EC ELECTRIC MOTOR
5. PLASTIC PARTS OF THE CONTROL SYSTEM
  - A. TRANSFORMER
  - B. CONTROL BOARD
  - C. SECURING ELEMENTS
  - D. MAIN SWITCH
  - E. GLANDS
6. FILTERS WITH PLASTIC FRAME



#### 1. FLAP ACTUATORS



- a. Open the unit door
- b. The device contains electrical and electronic components and must not be disposed of as household waste, local and currently valid legal conditions must be respected
- c. Disassembly of the actuator is performed by loosening the caliper and removing it from the flap shaft
- d. Tools used , 



#### 2. DTS PSA PRESSURE SENSOR



- a. Open the unit door
- b. Pull to disconnect the rubber sampling hoses
- c. Remove the pressure gauge cover
- d. Disconnect the cable
- e. Remove the sensor
- f. Tools used , 

#### 3. FAN IMPELLERS



- a. Open the unit door
- b. Disconnect the electric motor from the power supply and disconnect the ground cable of the fan frame
- c. Remove the impeller from the unit frame, remove the impeller from the unit
- d. Remove the electric motor from the impeller
- e. Tools used , , 

#### 4. PARTS OF ELECTRIC MOTORS OF FANS



- a. Remove the electric motor cover
- b. Remove the plastic bushings of the electric motor
- c. The procedure for disassembling the electric motor is contained in Annex 1 to this manual

#### 5. PLASTIC PARTS OF THE CONTROL SYSTEM

1. Voltage transformer
2. Control board
3. Securing elements
4. Main switch
5. Glands

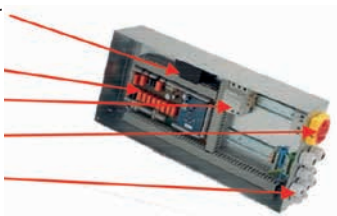

- a. Open the cabinet cover
- b. Disconnect cables
- c. Remove parts 1, 2, 3, 4, 5
- d. Tools used 

#### 6. FILTERS WITH PLASTIC FRAME

- a. Open the unit door
- b. Slide out the filters
- c. Tools used 





# DISASSEMBLE INSTRUCTIONS

[www.elektrodesign.cz](http://www.elektrodesign.cz)

EC blue motors with external rotor sizes  
B (090), D (116) and G (152).

### 1. GENERAL

This manual is used for disassembly and ecologically meaningful disposal of ECblue engine components with external rotor according to Regulation (EU) No. 1253/2014. It applies to motor sizes "B" (090), "D" (116) and "G" (152).

The design size of the motor is identified by the type designation (see rating plate).

#### Examples for type identification by means of the motor design size B = 90

Motor type	Type of axial fan	Type of radial fan
MK090 - _ I . . . . .	F _ _ _ _ - _ I . . B _ . . . . .	RH _ _ _ _ - _ I . . B _ . . . . .
		GR _ _ _ _ - _ I . . B _ . . . . .
		ER _ _ _ _ - _ I . . B _ . . . . .

### 2. SAFETY INSTRUCTIONS



#### CAUTION!

- The product installation instructions must be followed! Particularly all safety regulations must be adhered to!
- Risk of injury due to high magnetic attraction of the rotor and stator!

### 3. FAN DISASSEMBLY



#### RISK OF ELECTRIC SHOCK!

- 5 rules of the electric safety must be followed!
- During automatic motor operation, eg by air flow or deceleration after switching off, dangerous voltages higher than 50 V can be generated at the internal motor connections during operation of the generator.
- Due to the use of a capacitor, there is a risk of death even after switching off if it comes into direct contact with live parts or live parts.
- The control box can be removed or open only with the mains supply disconnected and after three minutes.

#### Procedure

1. Disconnect the mains voltage and secure against being switched on again.
2. Clean the fan of external dirt before disassembly.
3. Depending on the type of fan, external components such as the wall ring (2) and the support grille (1) must be removed and checked for reusability.



4. Remove the housing from the controller cover at the earliest after a waiting time of 3 minutes.
5. Check the no-power condition.
6. Disconnect or remove all electrical wiring.

#### 4. DISASSEMBLY TOOLS

The disassembly requires following tools:

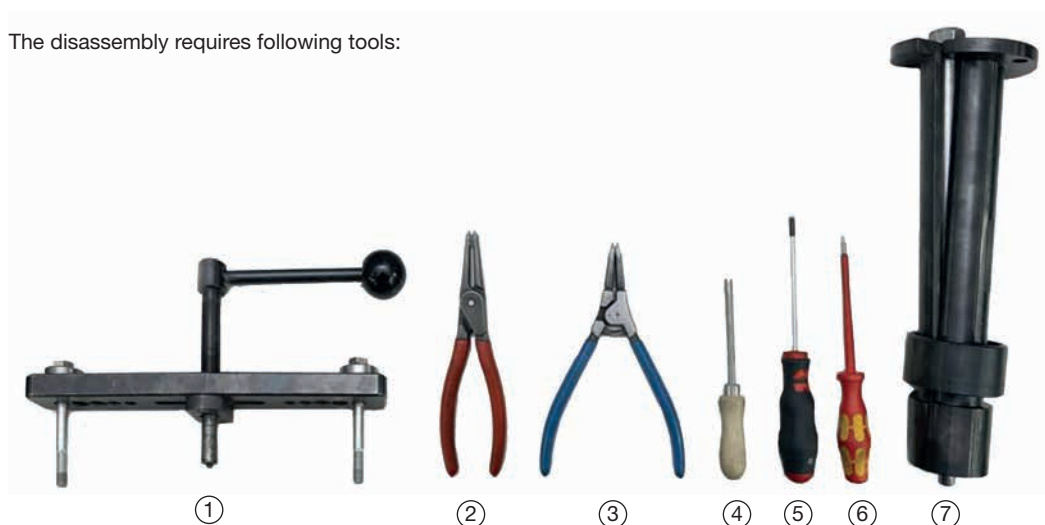

1. Beam expander
2. Pliers for the outer circlip
3. Pliers for inner circlip
4. Opening tool for motor sizes D (116) and G (152)
5. For motor sizes B (090) screwdriver TX20 (TR TX20 for Allen key), for motor sizes D (116) and G (152) screwdriver TX25
6. Slotted screwdriver (eg 0.6) for motor sizes D (116) and G (152)
7. Shrink sleeve including circular material for removing the ball bearing on the stator side

#### Special tools available from ZIEHL-ABEGG

Motor design size	Opening tool		Beam expander		Extracting sleeve	
	Drawing no.	Product nos.	Drawing no.	Product nos.	Drawing no.	Product nos.
B (090)	–	–	6003-201	00280698	6003-212	00703644
D (116)	6003-019	00161068	6003-202	00280682	6003-209	00295437
G (152)	6003-019	00161068	6003-202	00280682	6003-211	00296476

### 5. DISASSEMBLY PROCEDURE

#### 5.1 OPEN THE ENGINE

##### Remove the housing from the controller cover

- For motor size B (090)
- Loosen the 2 x Allen screw from the connection compartment cover with a “5” TX20 screwdriver.
- Loosen the TR safety Allen screw 4 times with a screwdriver „5“ TX20 from the controller cover.
- For motor size D (116), loosen the 5 screws (Kombi Torx T20) with a screwdriver „5“.
- For motor size G (152), loosen the 6 screws (Kombi Torx T20) with a screwdriver „5“.

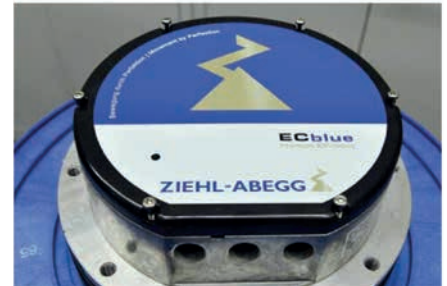

Illustration of motor size G (152)

##### Engine sizes D (116) and G (152)

- If necessary, remove the present add-on module from the connector.
- Loosen the locking pin with the opening or unlocking tool „4“.



**INFORMATION**  
Earlier versions are made with a plastic screw with a Torx T10 Allen screw, which must be loosened here.

- Push the retaining clips out with a screwdriver „6“ and remove the black inner cover.



#### 5.2 DISASSEMBLE THE ENGINE AND PULL OUT THE BALL BEARINGS

- Remove the inner circlip with pliers „3“ and discard.



**CAUTION!**  
Do not reuse the circlip due to the risk of overturning.

- Remove and dispose of the plastic plate.



**INFORMATION**  
The plastic plate is not in the design with hybrid bearings and steel shaft without plastic coating.



**CAUTION!**  
Do not reuse the plastic board.



- Remove the outer circlip with pliers „2“ and discard.

 **CAUTION!**  
Do not reuse the circlip due to the risk of overturning.

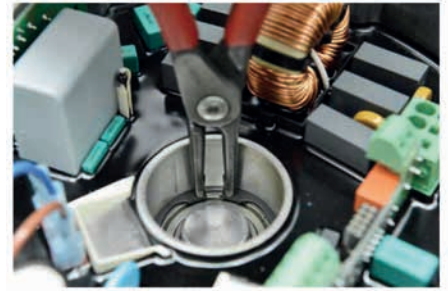

- Place the puller „1“ on the stator and fasten it to the stator flange.

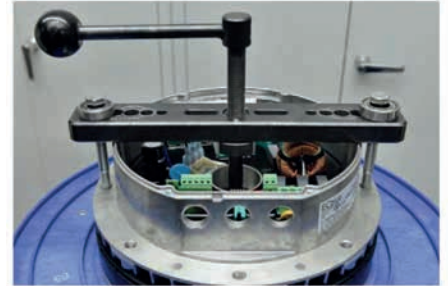

- Pull the stator „A“ away from the rotor using the spreader „1“ by pressing the threaded spindle on the front face „Z“.
- Pull the stator „A“ out of the magnetic field of the rotor „B“ using an expander.
- Remove the expander from the stator.

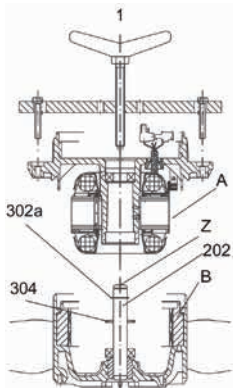

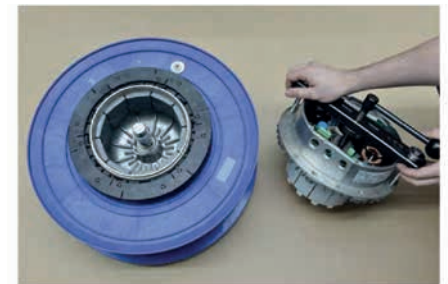

 **CAUTION!**

- Under no circumstances should you attempt to separate the stator from the motor manually without using an expander.
- Strong attraction between the stator A and rotor B is due to high electromagnetic forces – risk of injury!



- Remove and dispose of the plastic plate.

 **INFORMATION**  
The recent variants do not feature the plastic board and circlip!

 **CAUTION!**  
Do not reuse the circlip due to the risk of overturning.



- Remove and discard the lower circlip „302a“ using pliers „3“.

 **INFORMATION**  
The recent variants do not feature the plastic board and circlip!

 **CAUTION!**  
Do not reuse the circlip due to the risk of overturning.



- Remove the ball bearing on the stator side with a suitable round material.



- Use the shrink sleeve „7“ to remove the ball bearing on the rotor side.

If no suitable press is present, the ball bearing can also be moved using an expander and a shaft.



- Remove the plastic plate from the shaft and discard.



#### INFORMATION

- Only with rotor made of die-cast aluminum.
- For steel rotor versions, remove the plastic cooling wheel located on the bottom of the rotor and dispose of it.



Rotor made of die-cast aluminum with plastic plate (not shown) on the ring

- Remove the plastic cooling rings from the rotor flange with a suitable lifting tool (eg with a screwdriver “6”) and dispose of them.



#### INFORMATION

- For motor size G with steel rotor, loosen screw M5 instead with a screwdriver “5” TX25, then remove the cooling ring.



Steel rotor with plastic cooling wheel





**CAUTION!**  
Disassembled components shall not be reused!

## 6. DISPOSAL / RECYCLING

Disposal must be carried out professionally, ecologically and in accordance with the legal provisions in force in the respective country.

- Sort materials by type and ecologically
- If necessary, entrust the disposal to a specialist company